

SIEMENS

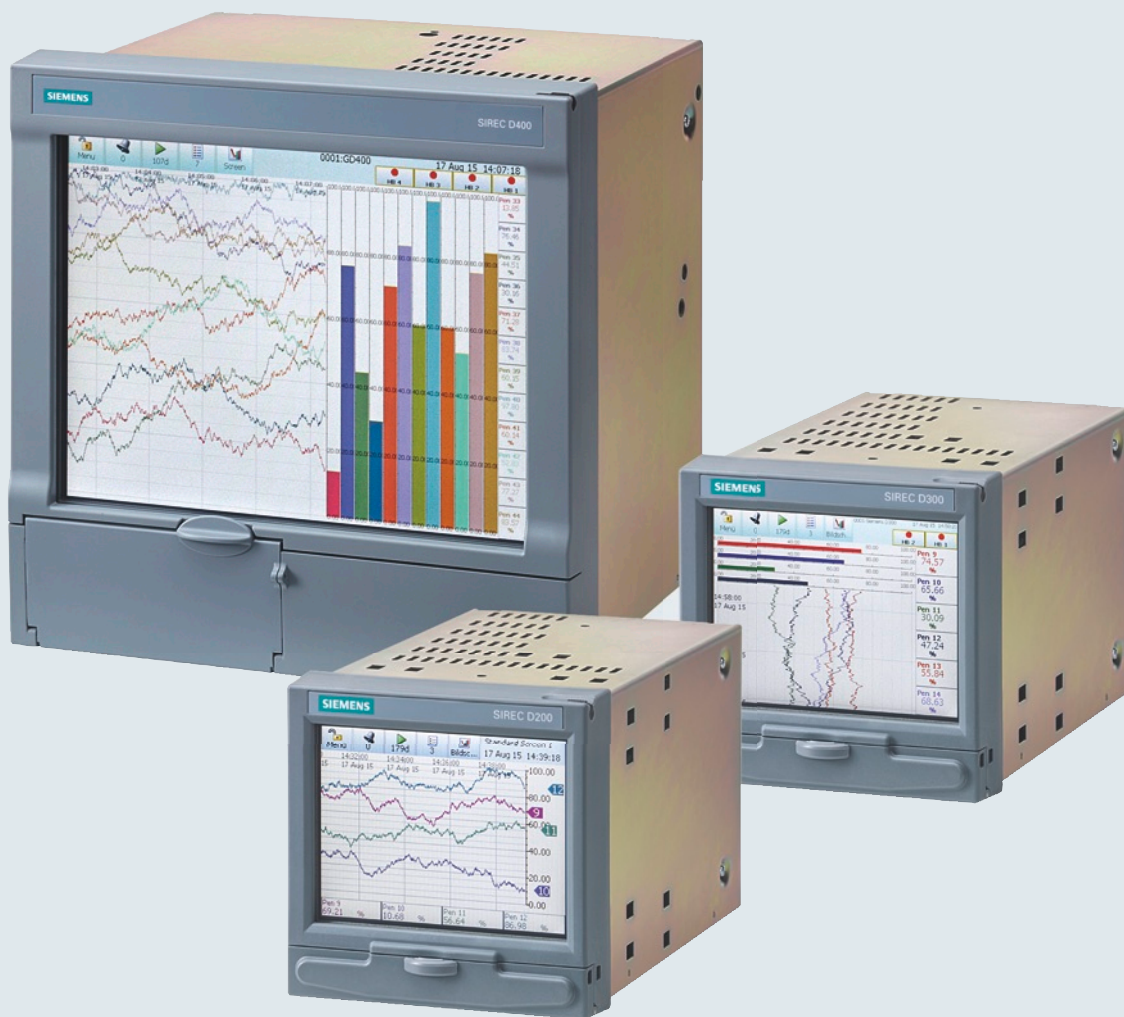

Process Recorders

Display Recorders







SIREC D

Catalog
MP 20

Edition
2017

www.siemens.com/sirec

Related catalogs

<p>Catalogs for Process Automation</p> <p>www.siemens.com/pa-catalogs</p>		<p>SIMATIC ST PCS 7 T SIMATIC PCS 7 Process Control System Technology components</p> <p>E86060-K4678-A141-A2-7600</p>	
<p>Process Automation FI 01 Field Instruments for Process Automation</p> <p>PDF (E86060-K6201-A101-C1-7600)</p>		<p>Industrial Communication IK PI SIMATIC NET</p> <p>E86060-K6710-A101-B8-7600</p>	
<p>Process Automation MP 31 SIPART Controllers and Software</p> <p>PDF/e-book (E86060-K6031-A100-B6-7600)</p>		<p>SITOP KT 10.1 Power supply SITOP</p> <p>E86060-K2410-A101-B2-7600</p>	
<p>Weighing Technology WT 10 Products for Weighing Technology</p> <p>PDF (E86060-K6410-A101-A5-7600)</p>		<p>SIMATIC Ident ID 10 Industrial Identification Systems</p> <p>E86060-K8310-A101-B1-7600</p>	
<p>Process Automation AP 01 Process Analytical Instruments</p> <p>E86060-K3501-A101-B3-7600</p>		<p>SITRAIN ITC Training for Industry</p> <p>Only available in German E86060-K6850-A101-C5</p>	
<p>Process Automation AP 11 Components for Continuous Emission Monitoring</p> <p>PDF (E86060-K3511-A100-B3-7600)</p>		<p>Products for Automation and Drives CA 01 Interactive Catalog, DVD</p> <p>E86060-D4001-A510-D7-7600</p>	
<p>SIMATIC ST PCS 7 SIMATIC PCS 7 Process Control System System components</p> <p>E86060-K4678-A111-C3-7600</p>		<p>Industry Mail Information and Ordering Platform in the Internet:</p> <p>www.siemens.com/industrymail</p>	
<p>SIMATIC ST PCS 7 AO Add-ons for the SIMATIC PCS 7 Process Control System</p> <p>E86060-K4678-A121-B2-7600</p>			

Display Recorders

SIREC D

Process Recorders



Catalog MP 20 · 2017

Supersedes:
Catalog MP 20 News · 2007

Refer to the Industry Mall for current updates of
this catalog:

www.siemens.com/industrymall

and as PDF at the following address:

www.siemens.com/pa-catalogs

For comfortable, fast and error free product selection you
will get support in our PIA Life Cycle Portal:

www.siemens.com/pia-portal

The products contained in this catalog can also be found
in the Interactive Catalog CA 01.

Article No.: E86060-D4001-A510-D7-7600 (DVD)

Please contact your local Siemens branch.

© Siemens AG 2016

SIREC D200

3

SIREC D300/SIREC D400

14

SIREC D application software

30

Appendix

Software licenses

Conditions of sale and delivery

32



The products and systems described in
this catalog are manufactured/distributed
under application of a certified quality
management system in accordance with
DIN EN ISO 9001.

Display Recorders



Product Overview

Overview

Comprehensive range for all requirements

SIREC process recorders are used in many industries. The SIREC D spectrum covers all important industries and areas - including environmental protection. Whether continuous monitoring of process parameters, system maintenance, process optimization or troubleshooting: the wide range of SIREC D products accommodates every requirement and delivers impressive performance along the entire production line.

SIREC D Display recorders

	SIREC D200	SIREC D300	SIREC D400
			
Description	The SIREC D200 is a competitive display recorder in 144 mm x 144 mm format with 5.7" color TFT-display	The SIREC D300 is a multifunctional display recorder in 144 mm x 144 mm format with 5.7" color TFT-display	The SIREC D400 is a high-end display recorder in 300 mm x 300 mm format with 12.1" color TFT-display
Channels	From 3 to 12 analog channels and up to 8 digital channels	From 8 to 16 analog channels and up to 16 digital channels	From 16 to 48 analog channels and up to 48 digital channels
Format	144 mm x 144 mm	144 mm x 144 mm	300 mm x 300 mm
Display	5.7" color TFT-display	5.7" color TFT-display	12.1" color TFT-display
Weight	About 3.2 kg	Max. 3.5 kg	Max. 10 kg
Type of protection	IP54 (NEMA 3)	IP54 (NEMA 3)	IP54 (NEMA 3)
Data buffer (intern)	1 GByte (optional 2 GByte)	1 GByte up to 4 GByte	1 GByte up to 4 GByte
Data buffer (extern)	Via USB Interface	Via USB Interface or by SD card	Via USB Interface or by SD card
Sampling rate	100 (optional)/200/500 ms for all channels	20 (optional)/100/200/500 ms for all channels	20 (optional)/100/200/500 ms for all channels
Interface	Ethernet TCP/IP	Ethernet, RS 485 Modbus, USB, slot for SD card	Ethernet, RS 485 Modbus, USB, slot for SD card
Operation	Touch-Screen with rapid navigation	Touch-Screen with rapid navigation	Touch-Screen with rapid navigation
Configuration	On device or by way of SIREC D Manager or Server-Software	On device or by way of SIREC D Manager or Server-Software	On device or by way of SIREC D Manager or Server-Software
Password protection	Up to 4 levels with up to 50 different users available	Up to 4 levels with up to 50 different users available	Up to 4 levels with up to 50 different users available
Options	Firmware options individual selectable by a flexible creditsystem	Firmware options individual selectable by a flexible creditsystem	Firmware options individual selectable by a flexible creditsystem

SIREC D Software

Various high-performance software packages are available as options for parameter setting, real-time display and storing, evaluation, analyzing and archiving.

SIREC D-Viewer (included in the scope of supply)

- Import of offline data from e.g. USB media and evaluating
- Display and printing of the imported data

SIREC D-Manager

- Offline data analysis of stored data
- Display, export and printing of imported data
- Archiving of measurement data

SIREC D-Server

- Network-compatible software package for connection of an unlimited number of recorders
- Communication via Ethernet/TCP/IP
- Real-time or FTP data transfer
- Display, export (CSV files) and printing of measurement data
- Archiving of measurement data

SIREC D-Designer

- Customized displays for SIREC D300 and SIREC D400
- Customer specific and application related
- Customized display combinations with bar graphs, trends, digitals

Overview

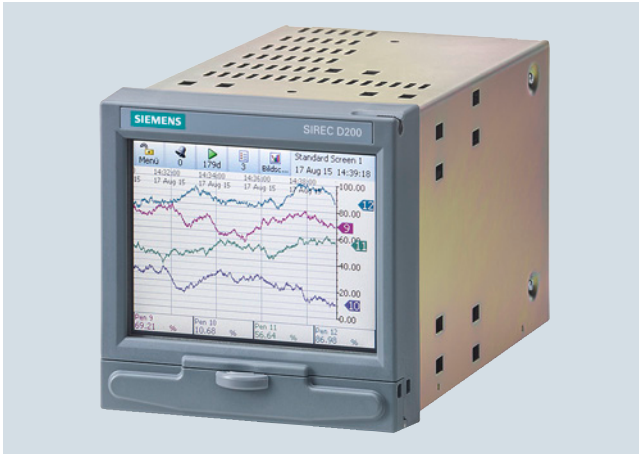

Crystal Clear Display

- 5.7" Digital Colour LCD (TFT)
- QVGA Resolution (320 x 240 pixels)
- Clear and intuitive operation
- Industrial rugged Touch Screen with rapid navigation

Comprehensive Connectivity

- 10/100 Ethernet (DHCP), web and e-mail
- FTP and TCP/IP
- Front USB port as standard for keyboard and mouse. Optional SD Card slot.

Data Storage

- On-board non-volatile memory - up to 2 GByte
- Removable USB storage
- No moving parts - all solid state Flash memory

Security Stringent - Total Data integrity

- Password Protection - 21CFR Part 11
- ESS - Extended Security System
- Password Network Synchronization

Plus..

- Health Watch for preventative maintenance
- Remote Access - Advanced Software Data Analysis at your PC
- Independent Chart and Logging speeds
- Global Language Support
- Rapid review and replay of data at recorder
- Approvals - CE
- NEMA 4X/IP66 (option)
- Up to 10 Hz (100 ms) Logging (including expansion card option)
- Up to 12 Analog Inputs
- Remote Viewing Tool
- 4 Pulse Inputs via the Digital I/O card (option)
- Concurrent Batch mode
- AMS2750 Process Capabilities

Function

Display

5.7" Colour Active TFT

With more than 256 000 colours makes it easy to interpret process data and take action with the intuitive bar charts, digital values, trends or trends displays. A screen saver function can be set from 1 to 720 minutes to extend the life of the backlight.

Touch Screen

The heavy duty durable touch screen provides easy data entry and rapid navigation through the menus. The touch screen operator interface provides fast, easy access to the recorder menus making set up and data analysis quick and efficient.

Navigation through the menus and text entry are direct and intuitive:

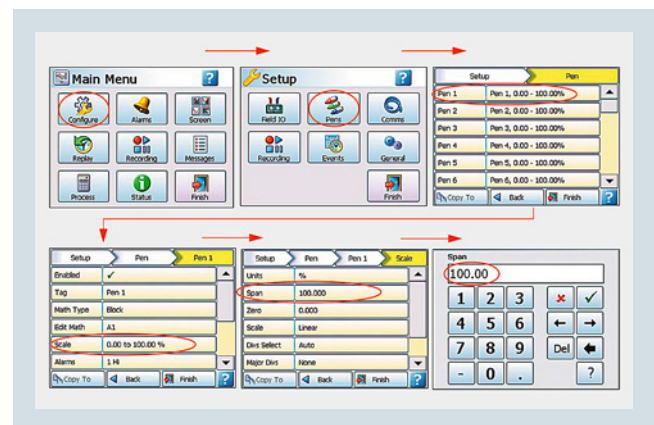

Example of a recorder menu path from the Main Menu to Pen Scale configuration with clear and rapid navigation

Standard Screens

Up to 12 screens displaying multiple combinations of Charts, Bars and Digitals can be configured, 6 examples below.

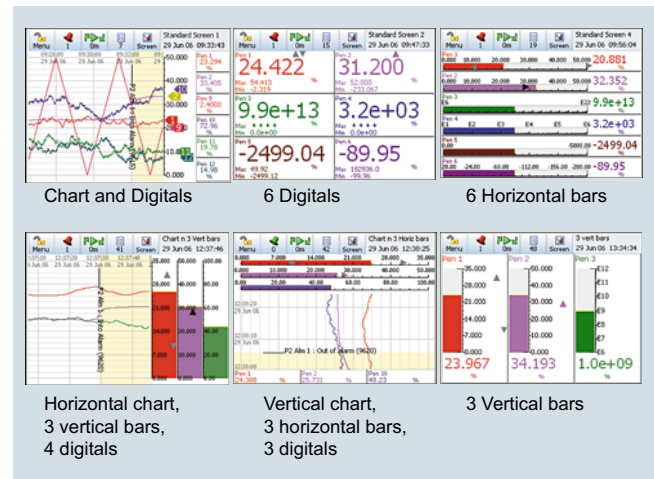

Help Files

A complete contextual help system can be accessed and visualised on the screen of the recorder.

Display Recorders

SIREC D200

Logarithmic Scales

All displayed scales can be set as linear or logarithmic.

Replay with Zoom

Select replay mode and zoom-in on a specific area on the screen. The data can easily be replayed at the recorder with the ability to "zoom". The touch screen makes it fast to review and analyse historical data. A "jump" function allows you to go from any message list directly to the trend showing the occurrence of the alarm.

Language Support

Standard language prompts for

- English UK & US
- French
- German
- Italian
- Spanish
- Brazilian
- Polish
- Hungarian
- Slovakian
- Czech
- Turkish
- Romanian
- Russian
- Greek
- Portuguese
- Bulgarian
- Chinese
- Japanese
- Korean

Communications

The recorder supports FTP, Modbus TCP/IP (slave mode), web and email over Ethernet (DHCP standard) communications. USB port allow the use of an ASCII barcode reader. Email sent to your network connected PC triggered by an Alarm or an Event.

Ethernet Connectivity

The Ethernet (DHCP standard) connection, with support for various protocols, provides unlimited connectivity to local area networks (LANs). The standard Ethernet interface makes networking of the recorder to a LAN or the world wide web fast and convenient. Dynamic Host Configuration Protocol (DHCP) automatically acquires the settings (IP address) for network communications from a DHCP server.

Simple Network Time Protocol (SNTP)

The recorder can be synchronised over the ethernet network via a SNTP client or synchronise other recorders via a Server.

Web Server

With the recorder connected to a LAN, all process variables, alarm and messages can be viewed from an internet browser; values are automatically refreshed.

USB Port

Front USB host port for data and setup transfers or remote screen through this port. Use these port to attach external devices (keyboard or mouse), for direct interfacing with the recorder.

Remote Viewer

Extends the user interface of the recorder onto the desktop PC. Providing remote viewing of the unit launched from a web browser. Full remote control is available as an option. Compatible with Microsoft™ Internet explorer 6 and higher.

Data Storage

Internal Data Storage

1 GByte to 2 GByte expandable internal non-volatile flash memory is available for data storage and chart history.

Pens	1 GByte	2 GByte
3	1 500 Days	3 000 Days
6	750 Days	1 500 Days
12	375 Days	750 Days

Internal memory (Logging rate = 1 s)

Data Export

Removable USB flash storage device. Data is stored in a secure binary encrypted format, with the recorder's configurations, providing added security of the data files

Events

Certain conditions or operations can be set up and logged according to the time and date of the occurrence. Subsequently events can be reviewed in a list or represented on a graph.

Batch

Batch enhances the management of data collected in non-continuous process, known as batch processing, used in thermal treatment, sterilisation, food processing and chemical reactions.

Soft Alarms

6 "software" alarms per pen are easily set up to display and record selected out-of-limit conditions. These can be tied to the relay or digital outputs to activate the user's external equipment.

Independent Display Chart Speeds and Logging rates

Logging rates can be programmed completely separate from the chart display speed, allowing the data to be displayed and stored at the rates that best suits the application.

Fuzzy Logging

This standard feature provides a unique method to increase the storage capacity of the recorder. The data is monitored to determine changes in process data; if no changes are observed data is logged periodically. If data is changing rapidly, it is recorded normally at the programmed rate. By not logging data that is static, data compression of 100:1 or more can be achieved saving valuable memory.

Pulse Inputs

The 8 Digital I/O option card has 4 channels that can be set as pulse inputs (first 4 channels). The operating frequency for pulse inputs on the Digital I/O card is 1 kHz max.

Data Security

Total Data Integrity

Data is stored in secure encrypted files making it easy to retrieve the data dependent on process information. Data is automatically recognised without having to remember file names.

Password Protection

Up to 4 levels of password protection with up to 50 different users are available. Multiple levels of password protection and an audit trail of actions enhance the security of the data.

Extended Security System (option)

ESS provides extended features including entry of unique User ID's and associate passwords, time-out of password entry, password expiration, and traceability of user actions. ESS is compatible with the requirements of 21CFR part 11.

Password Network Synchronization

Passwords can be synchronized over the network.

Safety StandardsCE Mark

Conformity with 2014/35/EC, Low Voltage Directive and 2014/30/EC EMC Directive.

Enclosure rating

Standard NEMA 3/IP54 type front face protection. NEMA 4X/IP66 available as an option.

Security tag

"Wire seal provision" that provides added security to seal the front door and rear wiring when using optional rear cover to prevent undetected entry to these areas of the recorder.

Technical specifications**Design Attributes**

Display size and Type	5.7" diagonal, color Diagonal, Digital Colour LCD (TFT) with Touch Screen Industrial grade with brightness adjustment and wide viewing angle
Resolution	QVGA (320 x 240 pixels)
Screen Saver	Set in minutes from 1 ... 720, can be set to dim the screen or to switch off. Automatic wake-up facility in the case of an alarm
Brightness adjustment	Adjustable between 10 and 100 %, default set to 80 % brightness
Backlight life time	50 000 hours to half brightness when used at 100 %. Maximum luminosity 450 cd/m ²
Touch Screen life	1 000 000 touches
Display Update Rate	Display values updated every second
Status Display	A status bar, at the top of the recorder's screen, displays the real-time icons of the recorder status, such as recording time left and alarm active.
Communications	Ethernet 10/100 base - T with RJ45 connector supporting Modbus/TCP, FTP, Internet, DHCP or fixed IP address.

Mathematics	Basic maths include Add, Subtract, Multiply, Divide, Modulo and power. Full Maths (option) support up to 100 character free form math expression for each pen. Like SINE, COS, TAN, Log, Parenthesis (eg. A1 + A2), comm variables, free memory, and access to any data item variable (A1, P1, D1 etc.)
Front USB Port	Front USB host port for data and setup transfers. External devices keyboard or mouse, Barcode reader, or external mass storage device. (USB 2.0 compliant)
Standard Screens	Fully programmable display values in engineering units. Time & date stamp on every division. Sets of Standard screens are available to display data on a chart, digital reading, bargraphs or numerous combinations thereof. Screen properties can be modified on the recorder and customised to suit. Digital values displayed include: <ul style="list-style-type: none"> • Alarms on bars • Engineering units • Pen name • Tag, time and date • 20 character description • Totalised values
Data Storage	<ul style="list-style-type: none"> • Local Mass Storage Options <ul style="list-style-type: none"> • USB memory key - must be formatted • USB hard drive - up to 120 GByte • Internal Data Buffer • Setup and screens • Manual Saving • Data Saving Period • Data Format • Recycling Mode
Power Requirements	<ul style="list-style-type: none"> • Voltage (VRMS) 100 V AC ... 250 V AC (auto select) • Frequency 50/60 Hz • Power Consumption < 40 W • 24 V optional instrument power 12 ... 30 V DC / 12 ... 20 V AC Power Consumption: < 40 W
Battery	Battery backed up for clock, replaceable lithium battery Type 6032, 3.0 V – 10 years life (Recorder powered), 4 years life, typical (Recorder unpowered).

Display Recorders

SIREC D200

Password Protection <ul style="list-style-type: none"> • Engineer • Supervisor • Technician • Operator Languages	Multiple Administrator control of password setup and management with four levels of password protection for – Engineer, Supervisor, Technician, and Operator. Up to 50 different users are available. Password protection restricts user entry to the recorder set up and specific screens. Highest access to all levels, Supervisor, Technician and Operator 2nd highest level including Technician and Operator access 3rd level including Operator access 4th and lowest level of access <ul style="list-style-type: none"> • English UK & US • French • German • Italian • Spanish • Brazilian • Polish • Hungarian • Slovakian • Czech • Turkish • Romanian • Russian • Greek • Portuguese • Bulgarian • Chinese • Japanese • Korean 	Display Chart Speeds <ul style="list-style-type: none"> • Chart rates 	<ul style="list-style-type: none"> • 1 mm/h • 5 mm/h • 10 mm/h • 20 mm/h • 30 mm/h • 60 mm/h • 120 mm/h • 600 mm/h • 1200 mm/h • 6000 mm/h Combinations of rates can be mixed and chart speeds can be set independently for each chart. Display speeds are independent of logging rate
Temperature Units Recorder Identification Clock <ul style="list-style-type: none"> • Accuracy 	°C, °F, K Status bar: Alternately displays Recorder ID and Recorder Screen Name, Displays Time and Date ± 20 ppm (± 1 minute/month) at 25 °C Summer/Winter manual or automatic time adjustment or via communications. SNTP Client and/or Server included for synchronising over Ethernet	Messages Screen CE Conformity (CE Mark) Immunity Product Classification	The message screen displays system information and records any setup activity that has been changed. It also provides warning and error message updates, lists alarm activity and will display user defined marks on a chart This product conforms with the protection requirements of the following European Council Directives: 2014/35/EC, the Low Voltage Directive, and 2014/30/EC, the EMC Directive. Conformity of this product with any other "CE Mark" Directive(s) shall not be assumed. Complies with EN 61326-1:2013 Class I: Cord Connected, Panel Mounted Industrial Control Equipment with protective earthing (grounding), (EN 61010-1:2010)
Alarm Set Points <ul style="list-style-type: none"> • Alarm triggers • Alarm Damping • Hysteresis 	6 per pen integral "soft" alarm set points easily set by user to announce selected out of limit conditions; user can select if an alarm triggers a change in the chart background colour Alarm triggers can be set for Hi, Lo, Deviation. Latched alarms require acknowledgement from the operator 1 s ... 24 h ± 100 % of pen scale An alarm can change the log rate on the affected pen	Enclosure Rating Installation Requirements EMC Standards Safety	Front panel designed to NEMA 3/IP54 (Optional NEMA 4X/IP66) Category II: Overvoltage (EN 61010-1:2010) Pollution Degree 2 Emissions - EN 61326-1:2013 Class A Immunity - EN 61326-1:2013 Industrial Levels Complies with EN 61010-1: 2010 Panel Mounted Equipment, Terminals must be enclosed within the panel
Data Replay Mode	Data replay facility on chart displays at normal, fast or slow speeds with zoom and cursor. Jump facility from the alarm history list directly to the occurrence on the chart	Analog Inputs Number of Inputs Input Types Minimum Input Span Burnout (T/C) Cold Junction Compensation Input Resolution Input Impedance <ul style="list-style-type: none"> • Current loop resistance 	3, 6, 9 or 12 input channels mV, V, mA with external shunt (provided as standard), Thermocouple, RTD and ohms Range is fully configurable with span limitation of the operating range selected with 4 % under range to 4 % over-range capability (50 V Range 2 %) Active (High or Low), Passive and Health watch/maintenance (option) Internal compensation with the ability to manually adjust values, External Input for compensation, External CJC value specified 0.0015 % (16 Bit ADC) 10 Ω, use ± 0.1 % external resistor, Volts > 1 MΩ, all other > 10 MΩ

Source Impedance	100 Ω per lead maximum (a single point cal on Slot A will improve accuracy for a lead resistance above 10 Ω)		
• T/C and RTD			
Square Root Extraction	Available as standard on Volts and mA input types		
Sensor Compensation	Single point and Dual point for every input type		
Input Sampling Rate	Recorder has 2 available slots with up to 6 analog inputs each; first slot fixed		
• Analog Input card (standard)	200 ms (5 Hz), 500 ms (2 Hz)		
• Analog Input expansion card (option)	100 ms (10 Hz), 200 ms (5 Hz), 500 ms (2 Hz)		
Linear Scales	<ul style="list-style-type: none"> • Normal and Scientific notation • Decimal Point automatic or programmable • Engineering units, user definable (10 characters) 		
Logarithmic Scales			
• Logarithmic Decade limits	-38 min ... +38 max, (recommend up to 20 decades on one screen to ensure clarity)		
Input Isolation	300 V AC channel-to-channel, channel-to-ground (Resistance thermometers are not isolated for initial card, expansion card option RTs are isolated)		
Noise Rejection	At 50/60Hz ± 2 %		
• Analog Input card (standard)			
- Common mode	2 Hz = -120 dB, 5 Hz = -120 dB		
- Normal Mode	2 Hz = -80 dB, 5 Hz = -25 dB		
• Analog Input expansion card (option)			
- Common mode	2 Hz = -120 dB, 5 Hz = -120 dB, 10 Hz = -120 dB		
- Normal Mode	2 Hz = -85 dB, 5 Hz = -80 dB, 10 Hz = -48 dB		
Input Range Performance and Accuracy	For Analog Input standard and expansion cards		
Input Actuation (Linear)	Range		
• mV (DC)	-1000 ... +1000		
• V (DC)	-50 ... +50		
• mA	4 ... 20, 0 ... 20		
• 200 Ω	0 ... 200		
• 500 Ω	0 ... 500		
• 1000 Ω	0 ... 1000		
• 4000 Ω	0 ... 4000		
Thermocouples	Temperatur range		
• B	260 ... 538 °C (500 ... 1000 °F) 538 ... 1816 °C (1000 ... 3300 °F)		
• E	-270 ... -200 °C (-454 ... -328 °F) -200 ... -70 °C (-328 ... -94 °F) -70 ... +1000 °C (-94 ... +1832 °F)		
• J	-210 ... 0 °C (-346 ... +32 °F) 0 ... 1200 °C (32 ... 2192 °F)		
• K	-270 ... -70 °C (-454 ... -94 °F) -70 ... +1372 °C (-94 ... +2502 °F)		
• R	-50 ... +260 °C (-58 ... +500 °F) 260 ... 650 °C (500 ... 1202 °F) 650 ... 1768 °C (1202 ... 3214 °F)		
• S	-50 ... +260 °C (-58 ... +500 °F) 260 ... 1000 °C (500 ... 1832 °F) 1000 ... 1768 °C (1832 ... 3214 °F)		
• T	-270 ... -210 °C (-454 ... -346 °F) -210 ... +400 °C (-346 ... +752 °F)		
• L	-200 ... 0 °C (-328 ... +32 °F) 0 ... 900 °C (32 ... 1652 °F)		
• G (W_W26)		0 ... 100 °C (32 ... 212 °F) 100 ... 316 °C (212 ... 600 °F) 316 ... 830 °C (600 ... 1526 °F) 830 ... 1515 °C (1526 ... 2759 °F) 1515 ... 2315 °C (2759 ... 4119 °F)	
• C (W5, W26)		0 ... 180 °C (32 ... 356 °F) 180 ... 1220 °C (356 ... 2228 °F) 1220 ... 2315 °C (2228 ... 4199 °F)	
• M (NiMo-NiCo) (NNM90)		-50 ... +370 °C (-58 ... +698 °F) 370 ... 1410 °C (698 ... 2570 °F)	
• N (Nicosil Nisil)		-200 ... +100 °C (-328 ... +212 °F) 100 ... 1300 °C (212 ... 2372 °F)	
• Chromel/Copel		-50 ... +600 °C (-58 ... +1112 °F)	
• P (Platinel)		0 ... 1390 °C (32 ... 2534 °F)	
• D		0 ... 180 °C (32 ... 356 °F) 180 ... 1840 °C (356 ... 3344 °F) 1840 ... 2490 °C (3344 ... 4515 °F)	
Resistance thermometers		Temperatur range	
• Pt100 α = 0,00385		-200 ... +850 °C (-328 ... +1562 °F)	
• Pt 200 α = 0.00385		-200 ... +850 °C (-328 ... +1562 °F)	
• Pt 500 α = 0.00385		-200 ... +850 °C (-328 ... +1562 °F)	
• Pt 1000 α = 0.00385		-200 ... +850 °C (-328 ... +1562 °F)	
• Nickel, 100 Ω		-60 ... +180 °C (-76 ... +356 °F)	
• Nickel, 120 Ω		-80 ... +260 °C (-112 ... +500 °F)	
Logging			
Logging Method		Sample, Average, Min/Max - can be set independently per pen	
Logging Types		Continuous, Fuzzy	
Logging Rate		From 100 ms ... 60 h per Pen	
Fuzzy Logging		A secure data storage technique which delivers data compression ratio of 100:1 or more; self teaching, storing the data at a variable rate to match the process	
Mechanical Design			
Enclosure/Bezel		Zinc plated steel case with high impact resistant polycarbonate bezel; scratch resistant lens (Polyethylene Terephthalate). NEMA 3/IP54 protection rating standard. Optional NEMA 4X/IP66 (Front face only)	
• Enclosure Rating		Front panel designed to NEMA 3/IP54 (Optional NEMA 4X/IP66)	
• Colour		Bezel: Grey	
Mounting Panel		Unlimited mounting angle For the best view of the display the viewing angle should not exceed: <ul style="list-style-type: none"> • 45° from the left or right, • 10° looking down and • 30° looking up at the recorder display. Mounting adjustable for panel thickness of 2 mm ... 20 mm. Adapter kits available for covering existing panel cutouts.	
Dimensions (W x H x D) in mm		144 x 144 x 200 (5.67 x 5.67 x 7.87") Additional 80 mm (3.15") clearance recommended for a straight type power cable and signal connectors	
Cutout (W x H) in mm		138 x 138 mm (5.43 x 5.43")	
Weight		Max. 2.4 kg (5.3 lb)	
Wiring Connections		IEC Power Plug. Removable terminal strip for input and alarm connections	

Display Recorders

SIREC D200

Environmental and Operating Conditions

Ambient Temperature	0 °C ... 50 °C (32 °F ... 122 °F)
Relative Humidity (%RH)	10 ... 90
Vibration	
• Frequency (Hz)	0 ... 70
• Acceleration (g)	0.1
Mechanical Shock	
• Acceleration (g)	1
• Duration (ms)	30
Mounting Position from Vertical	
• Tilted Forward	40°
• Tilted Backward	65°
• Tilted to Side (±)	65°
Power Requirements	
• Mains Voltage (Vrms)	100 ... 250
• Low Voltage AC (Vrms)	20 ... 25
• DC Voltages	20 ... 30
• Frequency (Hz)	47 ... 63
Power Consumption	AC: < 40 W (max), DC: <40 W (max), typical 20 W
Warm Up	30 minutes minimum

Options

Alarm Outputs	Programmable alarm set points (6 per pen) can be configured to activate up to 8 outputs
• Update rate	200 ms for all alarms
• Number/Type	<ul style="list-style-type: none"> • 4 or 8 relay contacts SPDT, 3 A 240 V AC, 3 A 24 V AC/DC, 0.2 A 240 V DC (non-inductive, internally suppressed) • 8 I/O - SPNO 1 A 24 V DC (non-inductive, internally suppressed)
• Activation	Fully programmable internal alarm levels. Assignable to any relay output
Digital Input/Output	
• Quantity	• 8 I/O
	All channels may be selected freely as either digital inputs or outputs. The Digital I/O card also has 4 channels that can be set as pulse inputs (channels 1 ... 4). The operating frequency for pulse inputs on the Digital I/O card is 1kHz max.
- Inputs	Voltage free, isolated
- Outputs	4 relay outputs, all four channels are relay outputs only
• Relays/DI card	<ul style="list-style-type: none"> • 8 relays/ 2 DI card <p>2 outputs can be configured for use as digital inputs: A digital input is provided by a volt free contact between the normally open (NO) and the common (C) terminals of an output relay. If the 2 Digital inputs are used only 6 relay outputs are available. Closed < 500 Ω, Open > 300 kΩ</p>

E-mail	Setup email accounts to send the following: When an Alarm is triggered or an Email can be sent as a part of an Event occurring, such as: Alarms - In/Out/Ack, Totaliser – Start, Stop or Reset, Digital Inputs – On, Off or State change, TC Burnout – on a specific Analog Input channel, Scheduled Events – Once, Interval, Specific days, Month End
Events	User defined process events are recorded and can be set to cause particular recorder actions. Events can consist of recording start/stop, digital inputs, alarms, totalising actions, timers, barcode, etc. Once an event has been caused it can produce a definable set of effects on the recorder which can include, mark on chart, relay outputs, recording control, acknowledge alarm, trigger an Event, set/clear Relay, Screen change, E-mail a message and Reset max/mins. Each event marker can be recorded for analysis using the SIREC D application software.
Health Watch/Maintenance Capability	The recorder keeps track of important "life actions" for improved diagnostics and preventative maintenance notification. Including <ul style="list-style-type: none"> • Powered On • Last powered On • Time On since power up • Total On time • Total Off time • Longest Off time • Lithium cell life • Backlight life left at 100 % brightness • Hi/Lo CJC value (Hi & Lo temps), • Analog In last factory/ user calibration • Relay operations • Last configuration change
Transmitter Power	130 mA at 24 V DC ± 3 V DC
Extended Security System (ESS)	Provides full support for 21 CFR Part 11. Includes features for entry of unique User ID's and associated passwords: <ul style="list-style-type: none"> • Timeout on inactivity (1 ... 10 min) • Password expiration (1 ... 365 days) • Up to 50 users • Password re-entry lock out for incorrect entry of password more than 3 times, no re-use of passwords (programmable 4 ... 12 times) • Traceability by user name

Totaliser/Sterilisation	<p>One totaliser per input. Totaliser value must be assigned to a pen for display and storage.</p> <p>Multiple totalisations (Maths option) are possible with the use of extra pens (option). Reset may be manual or programmed. Totalisation values are 10 digits plus exponent.</p> <p>Each pen can be totalised according to the Fo or Po sterilisation* function at 121.11 °C (250 °F).</p> <p>The Standard Reference Temperature and Thermal Resistance (Z Value) are fully adjustable values of X, Y, W and V. Start temp, Reference temp and Z factor are all user defined, allowing support for many different types of sterilisation applications.</p> <p>Specification table for Sterilisation</p> <p>The definition of Fo/Po is the sterilisation/pasteurisation time in minutes required to destroy a stated number of organisms with a known z at temperature T.</p>
Batch	<p>The Batch function allows the user to segment portions of data for further analysis.</p> <p>Batch controls include:</p> <ul style="list-style-type: none"> • Start • Stop • Pause • For viewing • Resume and Abort
Print Support	<p>Network printing from status, message and replay screens. Plus screen capture facility of process screens instantly using a basic USB standard PCL printer.</p>
Math Algorithms	<p>All analog input channels have a math expression block. This is a fully user programmable 100 character free form math expression for each pen. Math calculations are available on all pens, one per input plus 12 extra pens for the SIREC D200 recorder.</p>
Miscellaneous	<p>Optional customer ID Tagging (3 lines of up to 22 characters each line)</p>

Display Recorders

SIREC D200

Firmware Credit System

The credits system is a flexible way of adding to the recorder features without having to upgrade the firmware. Simply purchase a number of credits to cover your current and possibly future requirements and the recorder will be delivered with the credits loaded. The credit value in each recorder is displayed in the Factory menu.

- Select the Options button and by activating and de-activating the options in the credit list, the recorder will change its functionality. Any greyed out options on the list will mean there are not enough credits available for that feature on the recorder.

Credits can be applied as desired to the Firmware functions until the total number of credits purchased has been used up. Additional credits can be purchased later if new features are to be activated and not enough credits are available to support these additional functions.

Firmware option	Credit value	Description
Full Maths	4	Full Math - this can handle math expressions that can consist of expressions up to 100 characters in length. (Note 1)
Full Maths with Scripting	6	A powerful multi-line scripting ability available to solve complex state based applications. Eg.: If .. X happens, then Y will happen, else .. Z will occur.' (Note 1)
Events	6	Events are certain conditions or operations that can be set up and logged according to the time and date of an occurrence. Subsequently events can be reviewed or displayed on a graph. Events can be set up to produce the following actions: Mark on Chart, start/stop Logging, start/stop/reset Totalisers, acknowledge alarm, trigger an Event, set/clear Relay, Screen change, E-mail a message and Reset max/mins. (Note 2)
Totalisers/ Sterilisation calculation	4	Each pen can be associated with a totaliser. Using extra pens, the totalised values can be displayed and recorded; multiple totals can be calculated out of the same variable (weekly, monthly, etc.). The totaliser function can handle Fo and Po sterilisation calculation. (Note 1)
Reports	3	Generate reports manually or using the event system to show daily/weekly/monthly Totals, Max/ Mins, Averages, Current Value, Messages, Message Lists - Alarm, System, Diagnostic, Security & User, Counters, Digital Inputs, and Digital Outputs. Reports can be printed, e-mailed as an attachment or exported to external media in RTF format.
AMS 2750 Process	5	AMS2750 Process activates the Process Mode screen and the AMS2750 process configuration menus for furnaces and sensors in accordance with AMS2750 specification, including Thermocouple tracking.
Health Watch/ Maintenance	2	The recorder keeps track of important "life actions" for improved diagnostics and preventative maintenance notification. Including Powered On, Last powered On, Time On since power up, Total On time, Total Off time, Longest Off time, Lithium cell life, Backlight life left at 100 % brightness, Hi/Lo CJC value (Hi & Lo temps), Analog In last factory/user cal, Relay operations.
Print Support	2	Network printing from status, message and replay screens. Plus screen capture facility of process screens instantly using a basic USB standard PCL printer.
Batch	5	The Batch function allows the user to segment portions of data for further analysis. Batch controls include Start, Stop, Pause, for viewing, Resume and Abort.
Modbus Master	10	Modbus master enables the recorder to communicate with up to 32 Slave devices on both Ethernet and RS485. The recorder itself can also act as a slave device while also being a master. RS485 is not available for SIREC D200.
Remote Viewer	3	Extends the user interface of the recorder onto the desktop PC. Providing full remote control of the unit launched from a web browser.
E-mail	3	Setup email accounts to send the following: When an Alarm is triggered or an Email can be sent as a part of an Event occurring, such as: Alarms - In/Out/Ack, Totaliser - Start, Stop or Reset, Digital Inputs - On, Off or State change, TC Burnout - on a specific Analog Input channel, Scheduled Events - Once, Interval, Specific days, Month End.
Pwd Net Sync	5	Password Network Synchronisation. Password can be synchronised over the network, a recorder can be designated as a master of a password group and other recorders can be added to that group as slaves, the master will ensure all passwords are synchronised with all recorders in its group.
Secure WSD	3	Secure WSD is a web service that can run on devices and conforms to the Devices Profile for Web Services (DPWS). Recorder device will host web service and have server certificate installed on it. Desktop clients will have root authority certificate of server in trusted root certificates. Whenever client connects to WSD service SSL handshake will take place and on successful handshaking secure communication channel will be established and data flowing between these two end points will be encrypted.
Extra Pens	2	4 extra pens to store and display totalised values, results of calculations, etc. Maximum is up to 12 extra pens for the SIREC D200 recorder.
Hardware Lock	2	Uses the password permission areas to lock access to the hardware configuration functionality leaving some areas view only.

Notes

- (1) Additional pens ("Extra Pens") can be used to display and store the results of calculations, totalisers, variables imported via communications, or to store values.
- (2) Event markers are required to automatically reset the totalisers, for example on a periodic basis or on an external condition. (Not necessary if the totalisers are reset manually)

Selection and ordering data

	Article-No.	Accessories	Article No.
SIREC D200 display recorder Front dimensions: 144 mm x 144 mm, for all standard applications/TFT display, Ethernet interface (rear side) and USB interface (front face) ↗ Click on the Article No. for the online configuration in the PIA Life Cycle Portal.	7ND4121- A - 2	Firmware options for SIREC D200 Code No. of recorder required 10 credits 20 credits 30 credits 40 credits	7ND4801-8AD 7ND4801-8BD 7ND4801-8CD 7ND4801-8DD
Power supply 50 or 60 Hz, 90 ... 240 V AC 24 V DC	1 4	Options/enabling of SIREC D software Code No. of recorder required Enabling of SIREC D-Manager Enabling of SIREC D-Server Upgrading of SIREC D-Manager to SIREC D-Server	7ND4800-8BA 7ND4800-8CA 7ND4800-8EA
Signal inputs Universal inputs (mA, mV, V, TC, RTD, R) • 3 inputs • 6 inputs • 12 inputs	A B C	SIREC D software Only for subsequent orders; software is included in delivery of recorder Evaluation software for SIREC D200/D300/D400 (on CD) incl. enabling for SIREC D-Viewer and manual for the software on CD in German, English, French	7ND4800-8AA
Switching outputs and inputs None (retrofitting digital input/digital output not possible) None (retrofitting digital input/digital output possible) 4 relays (240 V) 8 relays, of which 2 can be optionally configured as binary input (240 V) 8 binary outputs and inputs (24 V relay/freely-configurable)	0 1 2 3 4	Documentation Included on CD-ROM in scope of delivery SIREC D200 recorder manual • German (can also be downloaded from Internet) • English (can also be downloaded from Internet) • French (can only be downloaded from Internet)	A5E01001785 A5E01001767 A5E37588179
Internal data storage 1 GByte 2 GByte	3 4	Firmware options and required credits	
Transmitter power supply/rear side port None 24 V DC max. 200 mA	1 3	Options Groups/summarize channels Diagnostic functions Print Support 4 Extra Pens Counter Remote Viewer Batch/Groups E-mail function Totalisers Maths (free functions) Full Maths with Scripting Events (logical connections) Reports Modbus Master Secure WSD Hardware Lock Pwd Net Sync AMS 2750 Process	Required credits 2 2 2 2 3 3 5 3 4 4 6 6 3 10 3 2 5 5
Firmware options (see table below "Firmware options and required credits") None 10 credits 20 credits 30 credits 40 credits	A B C D E		
Extended Security System (ESS) IP54 protection rating standard (front face) • without ESS • with ESS	A B		
Scope of delivery: Recorder, CD-ROM with manual in German or English, SIREC D software (SIREC D-Viewer)			

Display Recorders

SIREC D200

Options

Options - Hardware

Alarm Card

- 4 or 8 outputs relay contacts SPCO 240 V
- 8 Digital I/O - SPNO 24 V DC
- Programmable alarm set points can be configured to activate up to 8 outputs

Portable Recorders

- Portable cases available as an accessory item

Digital Input

Two digital input options are available:

- 2 inputs on 8 channel Alarm card,
 - 8 inputs on Digital I/O card.
- The digital inputs allow users to initiate, from a remote location via a dry contact closure, selected recorder functions.

24 V AC/DC Power Supply

- 12 to 30 V DC
- 12 to 20 V AC

24 V DC Transmitter Power Supply

- Can supply up to 130 mA to external transmitters.

Print Support

- Network printing from status, message and replay screens. Plus screen capture facility of process screens instantly using a basic USB standard PCL printer.

Dimensional drawings

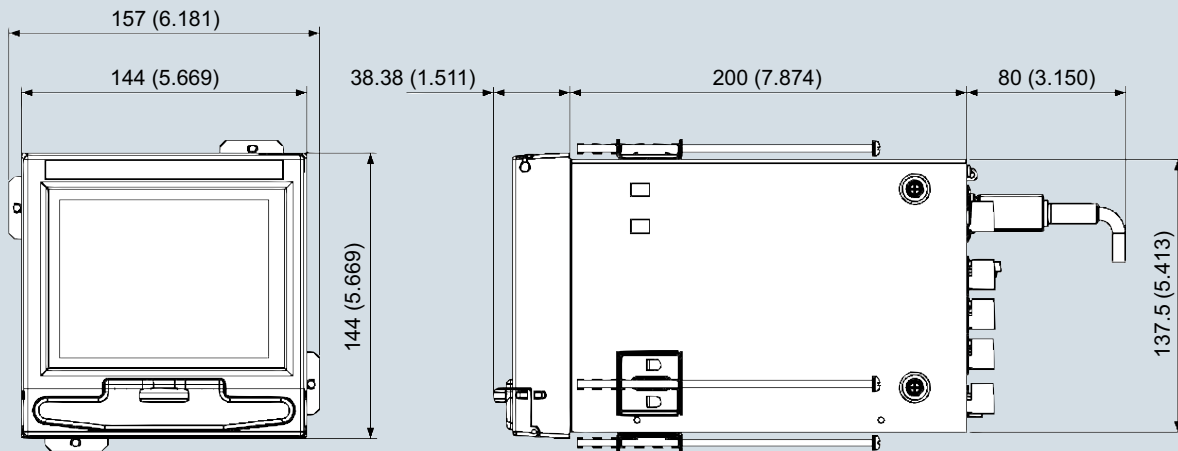

Two mounting brackets are supplied as standard

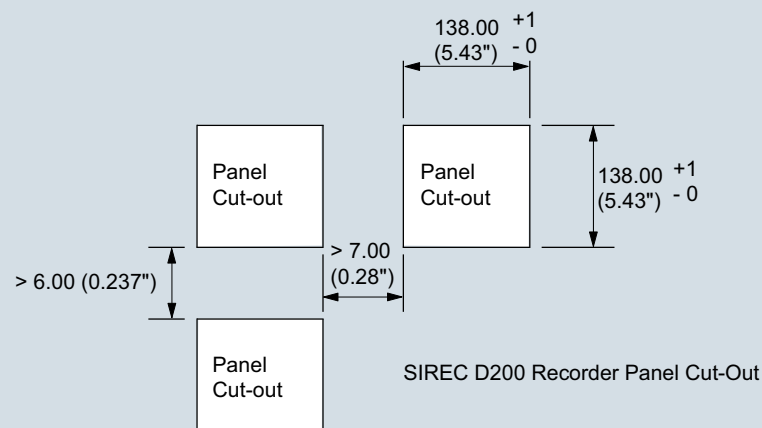

SIREC D200 Recorder Panel Cut-Out

SIREC D200, dimensions in mm (inch) and panel cut-out

Schematics

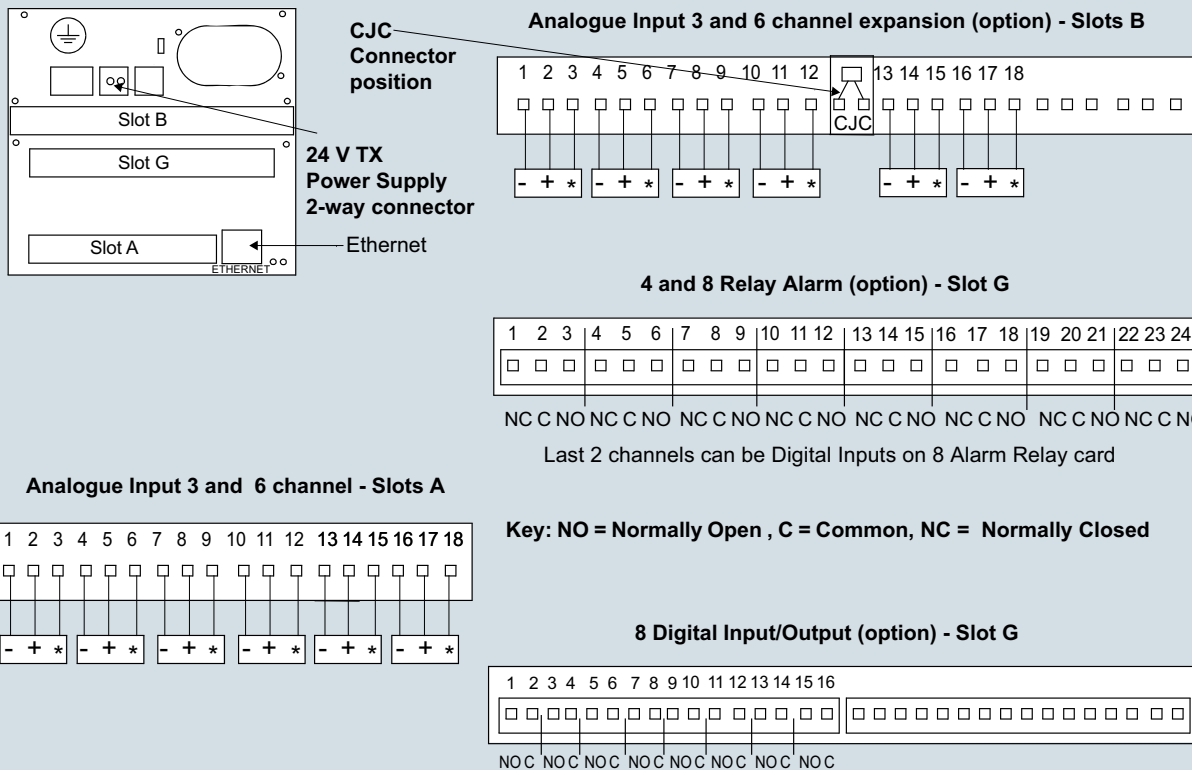

SIREC D200 - Terminal assignments and power requirements (rear of unit)

More information

Additional information is available in the Internet under:

<http://www.siemens.com/sirec>

Display Recorders

SIREC D300 and SIREC D400

Overview

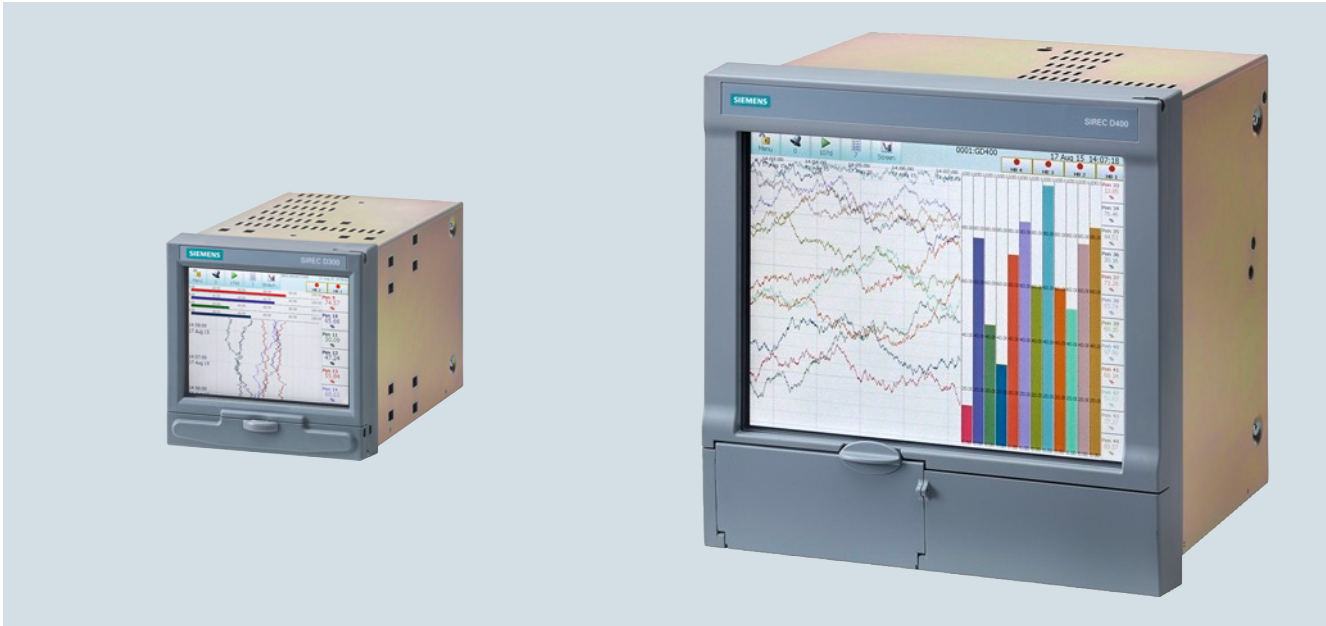

Crystal Clear Display

- Digital Colour LCD (TFT)
- Resolution
 - SIREC D300: VGA Resolution (640 x 480 pixels)
 - SIREC D400: XWGA Resolution (1024 x 768 pixels)
- Clear and intuitive operation
- Industrial rugged Touch Screen with rapid navigation
- Custom Screens

Comprehensive Connectivity

- 10/100 Ethernet (DHCP), web, e-mail
- FTP, TCP/IP and RS485 Modbus Protocol
- USB ports for keyboard and mouse

Data Storage

- On-board non-volatile memory - up to 4 GByte
- Removable SD card and USB storage
- No moving parts - all solid state data storage

Security Stringent - Total Data integrity

- Password Protection - 21CFR Part 11
- ESS - Extended Security System
- Password Network Synchronization

Plus..

- Health Watch for preventative maintenance
- Remote Access - Advanced Software Data Analysis
- Analysis at your PC
- Independent Chart and Logging speeds
- Global Language Support
- Rapid review and replay of data at recorder
- Approvals - CE
- NEMA 4X/IP66 (option)
- Up to 50 Hz (20 ms) Logging
- Analog Inputs
 - SIREC D300: Up to 16 Analog Inputs
 - SIREC D400: Up to 48 Analog Inputs
- Remote Viewing Tool
- Concurrent Batch Mode
- AMS2750 Capabilities

Function

Display

12.1" Digital Colour LCD TFT (SIREC D400)
 5.7" High Resolution Digital Colour LCD TFT (SIREC D300)

With more than 256 000 colours makes it easy to interpret process data and take action with the intuitive bar charts, digital values, trends or customised displays. A screen saver function can be set from 1 to 720 minutes to extend the life of the backlight.

Touch Screen

The heavy duty durable touch screen provides easy data entry and rapid navigation through the menus. The touch screen operator interface provides fast, easy access to the recorder menus making set up and data analysis quick and efficient.

Navigation through the menus and text entry are direct and intuitive:

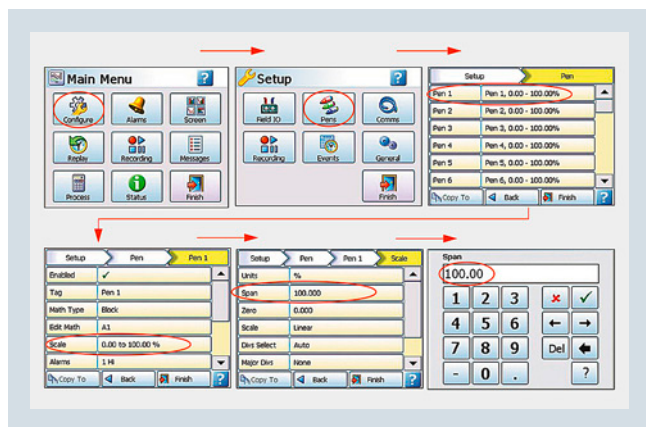

Example of a recorder menu path from the Main Menu to Pen Scale configuration with clear rapid navigation

Standard Screens

Up to 20 screens (SIREC D300) respectively 30 screens (SIREC D400) displaying multiple combinations of Charts, Bars and Digitals can be configured, 4 respectively 6 (SIREC D300) respectively SIREC D400) examples below.

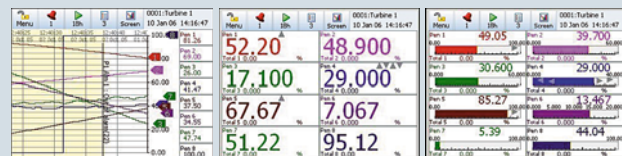
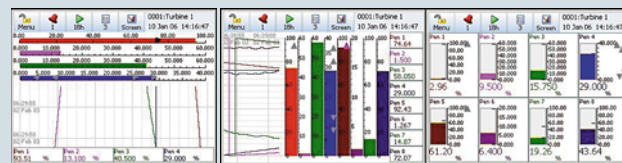

Chart and Digitals

8 Digitals

8 Horizontal bars



Vertical chart, 4 horizontal bars, 4 digitals

Horizontal chart, 8 vertical bars, 8 digitals

8 Vertical bars

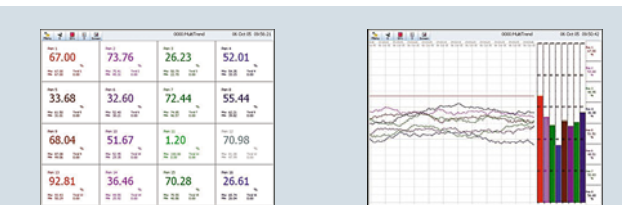

16 Digital Panel Meters

Horizontal Chart, 8 Vertical Bars and 8 Digital Panel Meters

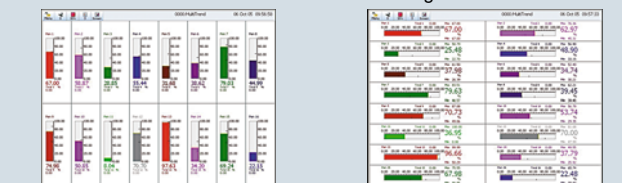

16 Vertical Bars

16 Horizontal Bars

Help Files

A complete contextual help system can be accessed and visualised on the screen of the recorder.

Logarithmic Scales

All displayed scales can be set as linear or logarithmic.

Replay with Zoom

Select replay mode and zoom-in on a specific area on the screen. The data can easily be replayed at the recorder with the ability to "zoom". The touch screen makes it fast to review and analyse historical data. A "Jump" function allows you to go from any message list directly to the trend showing the occurrence of the alarm.

Display Recorders

SIREC D300 and SIREC D400

Language Support

Standard language prompts for

- English UK & US
- French
- German
- Italian
- Spanish
- Brazilian
- Polish
- Hungarian
- Slovakian
- Czech
- Turkish
- Romanian
- Russian
- Greek
- Portuguese
- Bulgarian
- Chinese
- Japanese
- Korean

Communications

The recorder supports FTP, Modbus TCP/IP (slave mode), Web and Email over Ethernet (DHCP standard) communications port and Modbus RTU (slave mode) via an RS485 port. USB ports allow the use of an ASCII barcode reader. Email sent to your network connected PC triggered by an Alarm or an Event.

Ethernet Connectivity

The Ethernet (DHCP standard) connection, with support for various protocols, provides unlimited connectivity to local area networks (LANs). The standard Ethernet interface makes networking of the recorder to a LAN or the world wide web fast and convenient. Dynamic Host Configuration Protocol (DHCP) automatically acquires the settings (IP address) for network communications from a DHCP server.

RS485 Modbus

The RS485 connection allows process data to be transferred to other devices, or to record data received in Modbus RTU protocol (slave mode only).

Simple Network Time Protocol (SNTP)

The recorder can be synchronised over the ethernet network via a SNTP client or synchronise other recorders via a Server.

Web Server

With the recorder connected to a LAN, all process variables, alarm and messages can be viewed from an internet browser with automatic refresh.

USB Ports

Front and rear USB host ports for data and setup transfers or remote screen through this port. Front USB port is standard and the rear USB port is available with the Communications card option. Use these ports to attach external devices (keyboard or mouse), for direct interfacing with the recorder.

Common Relay Output

A separate relay alarm output at the rear of the unit can be set up as an alarm output.

Remote Viewer

Extends the user interface of the recorder onto the desktop PC. Providing remote viewing of the unit launched from a web browser. Full remote control is available as an option. Compatible with Microsoft™ Internet explorer 6 and higher.

Data Storage

Internal Data Storage

1 GByte to 4 GByte expandable internal non-volatile flash memory is available for data storage and chart history.

Pens	1 GByte	2 GByte	4 GByte
16	250 Days	311 Days	1 240 Days
32	62 Days	155 Days	310 Days
48	40	103 Days	206 Days
96	20	51 Days	103 Days

Internal memory (Logging rate = 1 s) - SIREC D400

Pens	1 GByte	2 GByte	4 GByte
4	1 000 Days	2 000 Days	4 000 Days
8	500 Days	1 000 Days	2 000 Days
16	250	500 Days	2 000 Days

Internal memory (Logging rate = 1 s) - SIREC D300

Data Export

Removable Secure Digital (SD) card and USB flash storage device provides multiple data storage alternatives. Data is stored in a secure binary encrypted format, with the recorder's configurations, providing added security of the data files.

Events

Certain conditions or operations can be set up and logged according to the time and date of the occurrence. Subsequently events can be reviewed in a list or represented on a graph.

Batch

Batch enhances the management of data collected in non-continuous process, known as batch processing, used in thermal treatment, sterilisation, food processing and chemical reactions.

Soft Alarms

6 "software" alarms per pen are easily set up to display and record selected out-of-limit conditions. These can be tied to the relay or digital outputs to activate the user's external equipment.

Independent Display Chart Speeds and Logging rates

Logging rates can be programmed completely separate from the chart display speed, allowing the data to be displayed and stored at the rates that best suits the application.

Fuzzy Logging

This standard feature provides a unique method to increase the storage capacity of the recorder. The data is monitored to determine changes in process data; if no changes are observed data is logged periodically. If data is changing rapidly, it is recorded normally at the programmed rate. By not logging data that is static, data compression of 100:1 or more can be achieved saving valuable memory.

Pulse Inputs

The 8 Digital I/O option card has 4 channels that can be set as pulse inputs (first 4 channels). The operating frequency for pulse inputs on the Digital I/O card is 1kHz max.

Data SecurityTotal Data Integrity

Data is stored in secure encrypted files making it easy to retrieve the data dependent on process information. Data is automatically recognised without having to remember file names.

Password Protection

Up to 4 levels of password protection with up to 50 different users are available. Multiple level of password protection and an audit trail of actions enhance the security of the data.

Extended Security System (option)

ESS provides extended features including entry of unique User ID's and associate passwords, time-out of password entry, password expiration, and traceability of user actions. ESS is compatible with the requirements of 21CFR part 11.

Password Network Synchronization

Password can be synchronised over the network, a recorder can be designated as a master of a password group and other recorders can be added to that group as slaves. The master will ensure all passwords are synchronised with all recorders in its group.

Safety StandardsCE Mark

Conformity with 2014/35/EC, Low Voltage Directive and 2014/30/EC EMC Directive.

Enclosure rating

Standard NEMA 3/IP54 type front face protection. NEMA 4X/IP66 available as an option.

Security tag

"Wire seal provision" that provides added security to seal the front door and rear wiring when using optional rear cover to prevent undetected entry to these areas of the recorder.

Display Recorders

SIREC D300 and SIREC D400

Technical specifications

Design Attributes

Display size and Type	Diagonal, Digital Colour LCD (TFT) with Touch Screen Industrial grade with brightness adjustment and wide viewing angle	Standard Screens and Custom Screens	Fully programmable display values in engineering units. Time & date stamp on every division.
<ul style="list-style-type: none"> SIREC D300 SIREC D400 	5.7" (14.5 cm) diagonal, color		Sets of Standard screens are available to display data on a chart, digital reading, bargraphs or numerous combinations thereof. Screen properties can be modified on the recorder and customised to suit. Custom screens created in the Screen Designer software can be imported into the recorder for specialist applications. Custom Screen firmware option is required.
Resolution	VGA (640 x 480 pixels)		Digital values displayed include
<ul style="list-style-type: none"> SIREC D300 SIREC D400 	XVGA (1024 x 768 pixels)		<ul style="list-style-type: none"> Alarms on bars Engineering units Pen name Measuring point number Tag, time and date 20 character description Totalised values
Screen Saver	Set in minutes from 1 ... 720, can be set to dim the screen or to switch off		
Brightness adjustment	Adjustable between 10 and 100 %, default set to 80 % brightness.		
Backlight life time		Data Storage	
<ul style="list-style-type: none"> SIREC D300 	55 000 hours to half brightness when used at 100 % (86 000 h if used at 80 %), maximum luminosity 400 cd/m ²	<ul style="list-style-type: none"> Removable Media Local Mass Storage Options 	SD card, supports up to 32 GByte
<ul style="list-style-type: none"> SIREC D400 	43 000 hours to half brightness when used at 100 % (67 000 h if used at 80 %), maximum luminosity 400 cd/m ²		<ul style="list-style-type: none"> USB memory key - must be formatted USB hard drive - up to 120 GByte
Display Update Rate	Display values updated every second	<ul style="list-style-type: none"> Internal Data Buffer 	Non-volatile, 256 GByte (56 million acquisition values) upwards to 3.7 GByte (4 800 Million points)
Status Display	A status bar, at the top of the recorder's screen, displays the real-time icons of the recorder status, such as Recording Time left and alarm active	<ul style="list-style-type: none"> Setup and screens 	Stored internally on non-volatile memory
Communications	Ethernet 10/100 base -T with RJ45 connector supporting Modbus/TCP, FTP, Internet, DHCP or fixed IP address. RS485 Modbus RTU (up to 115200 Baud Rate)	<ul style="list-style-type: none"> Manual Saving Data Saving Period 	Data saving by inserting compact flash card or USB memory stick
Mathematics	Basic Maths include Add, Subtract, Multiply, Divide, Modulo and power. Full Maths and Scripting (option) support up to 100 character free form math expression for each pen. For example SINE, COS, TAN, Log, Parenthesis (eg. A1 + A2), comm variables, free memory, and access to any data item variable (A1, P1, D1 etc.).	<ul style="list-style-type: none"> Data Format Recycling Mode 	Related to log rate, number of pens, totals and alarms.
Front and Rear USB Ports	USB host ports front and rear for data and setup transfers through these ports. External devices (keyboard or mouse), Barcode reader, or external mass storage device. (USB 1.1 compliant)	<ul style="list-style-type: none"> Power Requirements Voltage (VRMS) Frequency Power Consumption - SIREC D300 - SIREC D400 Optional instrument power Voltage - SIREC D300 - SIREC D400 	Each pen is capable of its own independent storage rate (20 ms ... 60 h) Binary encoded format
		Common Relay Output (SPNC)	Internal memory has FIFO (First In First Out) capability where the newest data over-writes the oldest data
		<ul style="list-style-type: none"> NC common alarm relay 	100 V AC ... 250 V AC (auto select) 50/60 Hz
		Battery	12 ... 30 V DC/12 ... 20 V AC Power Consumption: < 40 W 20 ... 55 V DC/20 ... 30 V AC Power Consumption: < 60 W
			2 contacts, normally open when the recorder is powered (no active alarms), rating 24 V, 1 A
			Battery backed up for clock, Lithium battery Type 6032, 3.0 V – 10 years life (Recorder powered), 1 year life, typical (Recorder unpowered)

Password Protection <ul style="list-style-type: none"> • Engineer • Supervisor • Technician • Operator Languages	Multiple Administrator control of password setup and management with 4 levels of password protection for – Engineer, Supervisor, Technician, and Operator. Up to 50 different users are available. Password protection restricts user entry to the recorder set up and specific screens. Highest access to all levels, Supervisor, Technician and Operator 2nd highest level including Technician and Operator access 3rd level including Operator access 4th and lowest level of access <ul style="list-style-type: none"> • English UK & US • French • German • Italian • Spanish • Brazilian • Polish • Hungarian • Slovakian • Czech • Turkish • Romanian • Russian • Greek • Portuguese • Bulgarian • Chinese • Japanese • Korean 	Display Chart Speeds <ul style="list-style-type: none"> • Chart rates 	<ul style="list-style-type: none"> • 1 mm/h • 5 mm/h • 10 mm/h • 20 mm/h • 30 mm/h • 60 mm/h • 120 mm/h • 600 mm/h • 1200 mm/h • 6000 mm/h Combinations of rates can be mixed and chart speeds can be set independently for each chart. Display speeds are independent of logging rate.
Temperature Units Recorder Identification Clock Alarm Set Points <ul style="list-style-type: none"> • Alarm triggers • Alarm Damping • Hysteresis • Common relay output Data Replay Mode	°C, °F oder K (Kelvin) Status bar: Alternately displays Recorder ID and Recorder Screen Name. Displays Time and Date. Accuracy: ± 29 ppm (± 1 minute/month) at 25°C. Summer/Winter manual or automatic time adjustment or via communications. SNTP Client and/or Server included for synchronising over Ethernet. 6 per pen integral "soft" alarm set points easily set by user to announce selected out of limit conditions; user can select if an alarm triggers a change in the screen background colour Alarm triggers can be set for Hi, Lo, Deviation (latched or unlatched) for alarm acknowledgement 1 s ... 24 h ± 100 % of pen scale 1 A , 24 V; can be activated on any alarm Data replay facility on chart displays at normal, fast or slow speeds with zoom and cursor	Messages Screen CE Conformity (CE Mark) Immunity Product Classification Enclosure Rating Installation Requirements EMC Standards Safety	The message screen displays system information and records any setup activity that has been changed. It also provides warning and error message updates, lists alarm activity and will display user defined marks on a chart. This product conforms with the protection requirements of 2014/35/EC, the Low Voltage Directive, and 2014/30/EC, the EMC Directive. Conformity of this product with any other "CE Mark" Directive(s) shall not be assumed. Complies with EN 61326-1:2013 Class I: Cord Connected, Panel Mounted Industrial Control Equipment with protective earthing (grounding), EN 61010-1:2010 Front panel designed to NEMA3/IP54 (Optional NEMA 4X/IP66) Category II: Overvoltage (EN 61010-1:2010) Pollution Degree 2 Emissions - EN 61326-1:2013 Class B Immunity - EN 61326-1:2013 Industrial Levels Complies with EN 61010-1: 2010 Panel Mounted Equipment, Terminals must be enclosed within the panel
		Analog Inputs Number of Inputs <ul style="list-style-type: none"> • SIREC D300 • SIREC D400 Input Types Minimum Input Span Burnout (T/C) Cold Junction Compensation Input Resolution	4, 6, 8, 12 or 16 input channels 4, 6, 8, 12, 16, 24, 32, 40 or 48 input channels mV, V, mA with external shunt (provided as standard), Thermocouple, RTD and ohms Range is fully configurable with span limitation of the operating range selected with 4 % under range to 4 % over-range capability (50 V Range 2 %) Active (High or Low), Passive and Health watch/maintenance (option). Internal compensation with the ability to manually adjust values, External Input for compensation, External CJC value specified 0.0015 % (16 Bit ADC)

Display Recorders

SIREC D300 and SIREC D400

Input Impedance <ul style="list-style-type: none"> Current loop resistance 	10 Ω, use ± 0.1 % external resistor, Volts > 1 MΩ, all other > 10 MΩ	<ul style="list-style-type: none"> Chromel/Copel P (Platinel) D 	-50 ... +600 °C (-58 ... +1112 °F) 0 ... 1390 °C (32 ... 2534 °F) 0 ... 180 °C (32 ... 356 °F) 180 ... 1840 °C (356 ... 3344 °F) 1840 ... 2490 °C (3344 ... 4515 °F)
Source Impedance <ul style="list-style-type: none"> T/C and RTD 	100 Ω per lead maximum (Cu10 = 15 Ω)	Resistance thermometers <ul style="list-style-type: none"> Pt100 α = 0,00385 Pt 200 Pt 500 Pt 1000 Nickel, 100 Ω Nickel, 120 Ω Cu10 Cu53 	Temperatur range -200 ... +850 °C (-328 ... +1562 °F) -200 ... +850 °C (-328 ... +1562 °F) -200 ... +850 °C (-328 ... +1562 °F) -200 ... +850 °C (-328 ... +1562 °F) -60 ... +180 °C (-76 ... +356 °F) -80 ... +260 °C (-112 ... +500 °F) -200 ... +260 °C (-328 ... +500 °F) 0 ... 150 °C (32 ... 302 °F)
Square Root Extraction	Available as standard on every input type		
Sensor Compensation	Single point and Dual point		
Input Sampling Rate <ul style="list-style-type: none"> SIREC D300 	Recorder has 2 available slots with up to 8 analog inputs each; the input sampling rate is dependent on actuation type		
<ul style="list-style-type: none"> SIREC D400 	Recorder has 6 available slots with up to 8 analog inputs each; the input sampling rate is dependent on actuation type		
<ul style="list-style-type: none"> All Inputs Fast Sampling 	100 ms (10 Hz), 200 ms (5 Hz), 500 ms (2 Hz) 20 ms (50 Hz) - mA, mV, Volts and Ohms only		
Linear Scales	<ul style="list-style-type: none"> Normal and Scientific notation Decimal Point automatic or programmable Engineering units, user definable (10 characters) 		
Logarithmic Scales	Logarithmic Decade limits: -38 min, to +38 max, (recommend up to 20 decades on one screen to ensure clarity)		
Input Isolation	300 V AC channel-to-channel, channel-to-ground		
Noise Rejection <ul style="list-style-type: none"> Common mode Normal Mode 	At 50/60Hz ± 2 % 2 Hz = -120 dB, 5 Hz = -120 dB, 10 Hz = -120 dB 2 Hz = -85 dB, 5 Hz = -80 dB, 10 Hz = -48 dB		
Input Actuation (Linear) <ul style="list-style-type: none"> mV (DC) V (DC) mA 200 Ω 500 Ω 1000 Ω 4000 Ω 	Range -1000 ... +1000 -50 ... +50 4 ... 20, 0 ... 20 0 ... 200 0 ... 500 0 ... 1000 0 ... 4000		
Thermocouples <ul style="list-style-type: none"> B E J K R S T L G (W_{W26}) C (W₅, W₂₆) M (NiMo-NiCo) (NNM90) N (Nicosil Nisil) 	Temperatur range 260 ... 538 °C (500 ... 1000 °F) 538 ... 1816 °C (1000 ... 3300 °F) -270 ... -200 °C (-454 ... -328 °F) -200 ... -70 °C (-328 ... -94 °F) -70 ... +1000 °C (-94 ... +1832 °F) -210 ... 0 °C (-346 ... +32 °F) 0 ... 1200 °C (32 ... 2192 °F) -270 ... -70 °C (-454 ... -94 °F) -70 ... +1372 °C (-94 ... +2502 °F) -50 ... +260 °C (-58 ... +500 °F) 260 ... 1768 °C (500 ... 3214 °F) -50 ... +260 °C (-58 ... +500 °F) 260 ... 1768 °C (500 ... 3214 °F) -270 ... -210 °C (-454 ... -346 °F) -210 ... +400 °C (-346 ... +752 °F) -200 ... 0 °C (-328 ... +32 °F) 0 ... 900 °C (32 ... 1652 °F) 0 ... 100 °C (32 ... 212 °F) 100 ... 316 °C (212 ... 601 °F) 316 ... 2315 °C (601 ... 4199 °F) 0 ... 180 °C (32 ... 356 °F) 180 ... 1220 °C (356 ... 2228 °F) 1220 ... 2315 °C (2228 ... 4199 °F) -50 ... +370 °C (-58 ... +698 °F) 370 ... 1410 °C (698 ... 2570 °F) -200 ... +100 °C (-328 ... +212 °F) 100 ... 1300 °C (212 ... 2372 °F)		
		Logging	
		Logging Method	Sample, Average, Min/Max - can be set independently per pen
		Logging Types	Continuous, Fuzzy
		Logging Rate	From 200 ms ... 60 h per Pen
		Fuzzy Logging	A secure data storage technique which delivers data compression ratio of 100:1 or more; self teaching, storing the data at a variable rate to match the process
		Mechanical Design	
		Enclosure/Bezel	Zinc plated steel case with high impact resistant polycarbonate bezel; scratch resistant lens
		<ul style="list-style-type: none"> Enclosure Rating 	<ul style="list-style-type: none"> NEMA 3/IP54 protection rating standard Optional NEMA 4X/IP66 (front face only)
		<ul style="list-style-type: none"> Colour 	Bezel: Grey
		Mounting Panel	Unlimited mounting angle For the best view of the display the viewing angle should not exceed: <u>SIREC D300</u> <ul style="list-style-type: none"> 55° from the left or right, 40° looking down and 50° looking up at the recorder display. <u>SIREC D400</u> <ul style="list-style-type: none"> 70° from the left or right, 45° looking down and 55° looking up at the recorder display. Mounting adjustable for panel thickness of 2 mm ... 20 mm. Adapter kits available for covering existing panel cutouts.
		Dimensions (W x H x D) in mm	Additional 80 mm (3.15") clearance recommended for a straight type power cable and signal connectors 144 x 144 x 200 (5.67 x 5.67 x 7.87") 300 x 300 x 247 (11.34 x 11.34 x 9.72")
		<ul style="list-style-type: none"> SIREC D300 SIREC D400 	
		Cutout (W x H) in mm	<ul style="list-style-type: none"> SIREC D300 SIREC D400 138 x 138 mm (5.43 x 5.43") 281 x 281 mm (11.06 x 11.06")
		Weight	<ul style="list-style-type: none"> SIREC D300 SIREC D400 Max. 3.5 kg (7.7 lb) Max. 10 kg (22 lb)
		Wiring Connections	IEC power plug. Removable terminal strip for input and alarm connections

Environmental and Operating Conditions Ambient Temperature Relative Humidity (%RH) Vibration • Frequency (Hz) • Acceleration (g) Mechanical Shock • Acceleration (g) • Duration (ms) Mounting Position from Vertical • Tilted Forward • Tilted Backward • Tilted to Side (±) Power Requirements • Mains Voltage (Vrms) • Low Voltage AC (Vrms) • DC Voltages • Frequency (Hz) Power Consumption • SIREC D300 • SIREC D400 Warm Up Seismic Qualification	0 °C ... 50 °C (32 °F ... 122 °F) 10 ... 90 0 ... 70 0.1 1 30 40° 65° 65° 100 ... 250 20 ... 30 20 ... 55 47 ... 63 AC: < 40 W (max), DC: < 40 W (max). Typical 20 W AC: < 60 W (max), DC: < 60 W (max) . Typical 30 W 30 minutes minimum Complies with IEEE 323-1974 and/or 1983 and IEEE 344-1975 and/or 1987 (optional)	<ul style="list-style-type: none"> • Relays/DI card Custom Screens E-mail Event marker Analog Outputs (Re-transmission Outputs) <ul style="list-style-type: none"> • Quantity <ul style="list-style-type: none"> - SIREC D300 - SIREC D400 • Update Rate • Accuracy • Type • Maximum Load Resistance • Resolution • Isolation Health Watch/Maintenance Capability	<ul style="list-style-type: none"> • 8 relays/ 2 DI card 2 outputs can be configured for use as digital inputs: A digital input is provided by a volt free contact between the normally open (NO) and the common (C) terminals of an output relay. If the 2 Digital inputs are used only 6 relay outputs are available. Closed < 500 Ω, Open > 300 kΩ Provides the capability in the recorder to accept custom screen designs from the Screen Designer. Setup email accounts to send the following: When an Alarm is triggered or an Email can be sent as a part of an Event occurring, such as: Alarms - In/Out/Ack, Totaliser – Start, Stop or Reset, Digital Inputs – On, Off or State change, TC Burnout – on a specific Analog Input channel, Scheduled Events – Once, Interval, Specific days, Month End User defined process events are recorded and can be set to cause particular recorder actions. Events can consist of recording start/stop, digital inputs, alarms, totalising actions, timers, barcode, etc. Once an event has been caused it can produce a definable set of effects on the recorder which can include, mark on chart, relay outputs, recording control, acknowledge alarm, trigger an Event, set/clear Relay, Screen change, E-mail a message and Reset max/min. Each event marker can be recorded for analysis using the SIREC D application software. Re-transmission outputs available; a pen drives each output. Analog inputs, totalised values or any mathematical result can be re-transmitted. 2 or 4 re-transmission outputs 2, 4, 6 or 8 re-transmission outputs 250 ms all channels ± 0.1 % (0 ... 500 Ω load), ± 0.25 % (500 Ω, 1 kΩ load) 0 ... 20 mA, 4 ... 20 mA 1 kΩ 0,002 % 300 V AC The recorder keeps track of important "life actions" for improved diagnostics and preventative maintenance notification. Including <ul style="list-style-type: none"> • Powered On • Last powered On • Time On since power up • Total On time • Total Off time • Longest Off time • Hardware/Firmware updates • Lithium cell life • Backlight life left at 100 % brightness • SD card insertions • Hi/Lo CJC value (Hi & Lo temps), • Analog In last factory/user calibration • Relay operations
Options Pulse Input • Quantity • Frequency • Input Alarm Outputs • Update rate • Number/Type • Activation Digital Input/Output • Quantity • Relay Outputs	4 isolated inputs per board 1 Hz ... 25 kHz, updated once per second Low < 1V, High > 4 V ... < 50 V or Volt free input: Low = short circuit, High = open circuit. Programmable alarm set points (6 per pen) can be configured to activate up to 16 (SIREC D300) respectively 48 outputs (SIREC D400) 200 ms for all alarms • 4 or 8 relay contacts SPDT, 3 A 240 V AC, 3 A 24 V AC/DC, 0.2A 240 V DC (non-inductive, internally suppressed) • 8 I/O or 16 I/O - SPNO, 1 A 24 V DC (non-inductive, internally suppressed) Fully programmable internal alarm levels. Assignable to any relay output • 8 I/O or 16 I/O All channels may be selected freely as either digital inputs or outputs. The Digital I/O card also has 4 channels that can be set as pulse inputs (channels 1 ... 4). The operating frequency for pulse inputs on the Digital I/O card is 1kHz max. • 4 relay outputs All four channels are relay outputs only		

Display Recorders

SIREC D300 and SIREC D400

Transmitter Power (optional)	<ul style="list-style-type: none"> • SIREC D300 • SIREC D400 	<p>200 mA at 24 V DC ± 3 V DC 1 A at 24 V DC ± 3 V DC</p>
Extended Security System (ESS)		<p>Provides full support for 21 CFR Part 11.</p> <p>Includes features for entry of unique User ID's and associated passwords:</p> <ul style="list-style-type: none"> • Timeout on inactivity (1 ... 10 min) • Password expiration (1 ... 365 days) • Up to 50 users • Password re-entry lock out for incorrect entry of password more than 3 times, no re-use of passwords (programmable 4 ... 12 times) • Traceability by user name
Totaliser/Sterilisation		<p>One totaliser per input. Totaliser value must be assigned to a pen for display and storage.</p> <p>Multiple totalisations (Maths option) are possible with the use of extra pens (option). Reset may be manual or programmed. Totalisation values are 10 digits plus exponent.</p> <p>Each pen can be totalised according to the Fo or Po sterilisation function at 121.11°C (250 °F).</p> <p>The Standard Reference Temperature and Thermal Resistance (Z Value) are fully adjustable values of X, Y, W and V. Start temp, Reference temp and Z factor are all user defined, allowing support for many different types of sterilisation applications.</p> <p>Specification table for Sterilisation</p> <p>The definition of Fo/Po is the sterilisation/pasteurisation time in minutes required to destroy a stated number of organisms with a known z at temperature T.</p>
Batch		<p>The Batch function allows the user to segment portions of data for further analysis.</p> <p>Batch controls include:</p> <ul style="list-style-type: none"> • Start • Stop • Pause • For viewing • Resume and abort
Print Support		<p>Network printing from status, message and replay screens. Plus screen capture facility of process screens instantly using a basic USB standard PCL printer.</p>
Math Algorithms		<p>All analog input channels have a math expression block. This is a fully user programmable 100 character free form math expression for each pen. Math calculations available on all pens, one per input plus 16 extra pens for the SIREC D300 and 48 extra pens for the SIREC D400 recorder. Scripting maths includes conditions and multi-line scripting in pen maths expressions. Allow functions, permanent variables and constants, timers. 500 characters maximum per pen.</p>
Miscellaneous		<p>Optional customer ID Tagging (3 lines of up to 22 characters each line)</p>

Firmware Credit System

The credits system is a flexible way of adding to the recorder features without having to upgrade the firmware. Simply purchase a number of credits to cover your current and possibly future requirements and the recorder will be delivered with the credits loaded. The credit value in each recorder is displayed in the Factory menu.

- Select the Options button and by activating and de-activating the options in the credit list, the recorder will change its functionality. Any greyed out options on the list will mean there are not enough credits available for that feature on the recorder.

Credits can be applied as desired to the Firmware functions until the total number of credits purchased has been used up. Additional credits can be purchased later if new features are to be activated and not enough credits are available to support these additional functions.

Firmware option	Credit value	Description
Full Maths	4	Full Math - this can handle math expressions that can consist of expressions up to 100 characters in length. (Note 1)
Full Maths with Scripting	6	A powerful multi-line scripting ability available to solve complex state based applications. Eg.: "If .. X happens, then Y will happen. else .. Z will occur." (Note 1)
Events	6	Events are certain conditions or operations that can be set up and logged according to the time and date of an occurrence. Subsequently events can be reviewed or displayed on a graph. Events can produce the following actions: Mark on Chart, start/stop Logging, Start/stop/reset Totalisers, Set/clear Relay (Digital), Acknowledge alarm, trigger an Event, Screen change, E-mail a message and Reset max/mins. (Note 3)
Fast Scanning mode	5	For fast processes, the scan rate and recording of the data can be set for up to 50 times per second (20 ms) for <ul style="list-style-type: none"> • SIREC D300: up to 8 inputs • SIREC D400: up to 16 inputs
Totalisers/ Sterilisation calculation	4	Each pen can be associated with a totaliser. Using extra pens, the totalised values can be displayed and recorded; multiple totals can be calculated out of the same variable (weekly, monthly, etc.). The totaliser function can handle Fo and Po sterilisation calculation. (Note 1)
Custom Screens	4	Import custom built screens that have been created in SIREC D-Designer. (Note 2)
Reports	3	Generate reports manually or using the event system to show daily/weekly/monthly Totals, Max/ Mins, Averages, Current Value. Messages, Message Lists - Alarm, System, Diagnostic, Security & User, Counters, Digital Inputs, and Digital Outputs. Reports can be printed, e-mailed as an attachment or exported to external media in RTF format.
AMS2750 Process	5	AMS2750 Process activates the Process Mode screen and the AMS2750 process configuration menus for furnaces and sensors in accordance with AMS2750 specification, including Thermocouple tracking.
Health Watch/ Maintenance	2	The recorder keeps track of important "life actions" for improved diagnostics and preventative maintenance notification. Including Powered On, Last powered On, Time On since power up, Total On time, Total Off time, Longest Off time, Lithium cell life, Backlight life left at 100 % brightness, Compact Flash insertions, Hi/Lo CJC value (Hi & Lo temps), Analog In last factory/user cal, Relay operations
Print Support	2	Enables the printer option to print text from various screens using a basic USB standard PCL printer.
Batch	5	The Batch function allows the user to segment portions of data for further analysis. Batch controls include Start, Stop, Pause, for viewing, Resume and Abort.
Modbus Master	10	Modbus master enables the recorder to communicate with up to 32 Slave devices on both Ethernet and RS485. The recorder itself can also act as a slave device while also being a master. RS485 is not available for SIREC D200.
Remote Viewer	3	Extends the user interface of the recorder onto the desktop PC. Providing full remote control of the unit launched from a web browser.
E-mail	3	Setup email accounts to send the following: When an Alarm is triggered or an Email can be sent as a part of an Event occurring, such as: Alarms - In/Out/Ack, Totaliser - Start, Stop or Reset, Digital Inputs - On, Off or State change, TC Burnout - on a specific Analog Input channel, Scheduled Events - Once, Interval, Specific days, Month End.
Pwd Net Sync	5	Password Network Synchronisation. Password can be synchronised over the network, a recorder can be designated as a master of a password group and other recorders can be added to that group as slaves, the master will ensure all passwords are synchronised with all recorders in its group.
Secure WSD	3	Secure WSD is a web service that can run on devices and conforms to the Devices Profile for Web Services (DPWS). Recorder device will host web service and have server certificate installed on it. Desktop clients will have root authority certificate of server in trusted root certificates. Whenever client connects to WSD service SSL handshake will take place and on successful handshaking secure communication channel will be established and data flowing between these two end points will be encrypted.
Extra Pens (4)	2	4 extra pens to store and display totalised values, results of calculations, etc. <ul style="list-style-type: none"> • SIREC D300: Maximum is up to 16 extra pens • SIREC D400: Maximum is up to 48 extra pens
Hardware Lock	2	Uses the password permission areas to lock access to the hardware configuration functionality leaving some areas view only.

Notes

- (1) Additional pens ("Extra Pens") can be used to display and store the results of calculations, totalisers, variables imported via communications, or to store values.
- (2) Screens from Screen Designer for SIREC D300 and SIREC D400 cannot be imported.
- (3) Event markers are required to automatically reset the totalisers, for example on a periodic basis or on an external condition. (Not necessary if the totalisers are reset manually).

Display Recorders

SIREC D300 and SIREC D400

Selection and ordering data

	Article-No.		Article-No.
SIREC D300 display recorder	7ND4421-		7ND4461-
Front dimensions: 144 mm x 144 mm, for all applications, Cycle time: 100 ms for mA, V, mV/500 ms for TC/RTD/R Rear side: Ethernet interface; RS485; USB Front face: slot for SD card; USB interface			
↗ Click on the Article No. for the online configuration in the PIA Life Cycle Portal.		↗ Click on the Article No. for the online configuration in the PIA Life Cycle Portal.	
Power supply		Power supply	
50 or 60 Hz, 90 ... 240 V AC		50 or 60 Hz, 90 ... 240 V AC	
• without transmitter power supply	1	• without transmitter power supply	1
• 24 V DC max. 200 mA transmitter power supply	2	• 24 V DC max. 200 mA transmitter power supply	2
24 V DC/AC, 50/60 Hz, without transmitter power supply	5	24/48 V DC/24 V AC, 50/60 Hz, without transmitter power supply	4
Analog inputs/ Pulse inputs		Analog inputs (slot allocation 1 ... 4)	
8 analog inputs		16 analog inputs	
• without analog outputs	A	• without pulse inputs	A
• 2 analog outputs	B	• 4 pulse inputs	B
• 4 analog outputs	C	• 8 pulse inputs	C
14 analog inputs, without analog outputs	D	24 analog inputs	
16 analog inputs, without analog outputs	E	• without pulse inputs	D
4 pulse inputs		• 4 pulse inputs	E
• without analog outputs	H	32 analog inputs	
• 2 analog outputs	J	• without pulse inputs	F
• 4 analog outputs	K	• 4 pulse inputs	G
• 8 analog inputs, without analog outputs	L	• 8 pulse inputs	H
8 pulse inputs, without analog outputs	M	• 12 pulse inputs	J
		• 16 pulse inputs	K
Switching outputs and inputs		Analog inputs/Pulse inputs (slot allocation 5 and 6)	
None	0	without analog inputs	
4 relays (240 V)	1	• without analog outputs	A
8 relays, of which 2 can be optionally configured as binary input (240 V)	2	• 2 analog outputs	B
8 binary outputs and inputs (24 V relay/freely-configurable)	3	• 4 analog outputs	C
16 binary outputs and inputs (24 V relay/freely-configurable)	4	8 analog inputs	
		• without analog outputs	D
		• 2 analog outputs	F
		16 analog inputs, without analog outputs	G
Internal data storage		Switching outputs and inputs (distributed on 3 slots)	
1 GByte (standard)	6	None	0
2 GByte	7	4 relays (240 V)	1
4 GByte	8	8 relays, of which 2 can be optionally configured as binary input (240 V)	2
Extended Security System (ESS)		16 relays, of which 4 can be optionally configured as binary input (240 V)	3
None	1	24 relays, of which 6 can be optionally configured as binary input (240 V)	4
With	2	8 binary outputs and inputs (24 V relay/freely-configurable)	5
Firmware options		16 binary outputs and inputs (24 V relay/freely-configurable/ 1 x 16)	6
(see table below "Firmware options and required credits")		24 binary outputs and inputs (24 V relay/freely-configurable/16 + 8)	7
None	A	48 binary outputs and inputs (24 V relay/freely-configurable/3 x 16)	8
10 credits	B	Internal data storage	
20 credits	C	1 GByte (standard)	6
30 credits	D	2 GByte	7
40 credits	E	4 GByte	8
50 credits	F		
60 credits	G		
Protection rating standard (front face)			
IP54			
• without earthquake-proof version	A		
• earthquake-proof version	E		

Scope of delivery:

Recorder, CD-ROM with manual in German or English, SIREC D software (SIREC D-Viewer).

Note: USB Key is included in the scope of delivery.

	Article-No.
SIREC D400 display recorder Front dimensions: 300 mm x 300 mm, for all applications	7ND4461-2
↗ Click on the Article No. for the online configuration in the PIA Life Cycle Portal.	
Extended Security System (ESS)	
None	1
With	2
Firmware options (see table "Firmware options and required credits")	
None	A
10 credits	B
20 credits	C
30 credits	D
40 credits	E
50 credits	F
60 credits	G
75 credits	H
Protection rating standard (front face)	
IP54	
• without earthquake-proof version	A
• earthquake-proof version	E

Scope of delivery:

Recorder, CD-ROM with manual in German or English,
SIREC D software (SIREC D-Viewer).
Note: USB Key is included in the scope of delivery.

Accessories	Article No.
Firmware options for SIREC D300 and SIREC D400 Code No. of recorder required	
10 credits	7ND4801-8AC
20 credits	7ND4801-8BC
30 credits	7ND4801-8CC
40 credits	7ND4801-8DC
50 credits	7ND4801-8EC
60 credits	7ND4801-8FC
70 credits (SIREC D400 only)	7ND4801-8GC
Options/enabling of SIREC D software Code No. of software required	
Enabling of SIREC D-Manager	7ND4800-8BA
Enabling of SIREC D-Server	7ND4800-8CA
Enabling of SIREC D-Designer (only for SIREC D300 and SIREC D400)	7ND4801-8DA
Upgrading of SIREC D-Manager to SIREC D- Server	7ND4800-8EA
SIREC D software Only for subsequent orders; software is included in delivery of recorder Evaluation software for SIREC D200/D300/ D400 (on CD) incl. enabling for SIREC D-Viewer and manual for the software on CD in German, English, French	7ND4800-8AA
Documentation Included on CD-ROM in scope of delivery SIREC D300 and SIREC D400 recorder man- ual	
• German (can also be downloaded from Internet)	A5E01001785-03
• English (can also be downloaded from Internet)	A5E01001767-03
• French (can only be downloaded from Internet)	A5E37588179

Firmware options and required credits**SIREC D300**

Options	Required credits
Diagnostic functions	2
Print support	2
4 extra pens (virtual channels)	2
8 extra pens (virtual channels)	4
16 extra pens (virtual channels)	8
Counter	3
Remote viewer	3
Batch	5
E-mail function	3
Totalisers	4
Maths (free functions)	4
Maths and Scripts (free functions)	6
Events (logical connections)	6
Custom specified screens	4
Fast scanning (20 ms/only with mV/V/mA)	5
Reports	3
Modbus Master	10
Secure WSD	3
Hardware Lock	2
Pwd Net Sync	5
AMS 2750 Process	5

SIREC D400

Options	Required credits
Diagnostic functions	2
Print support	2
4 extra pens (virtual channels)	2
8 extra pens (virtual channels)	4
16 extra pens (virtual channels)	8
32 extra pens (virtual channels)	16
48 extra pens (virtual channels)	24
Counter	3
Remote Viewer	3
Batch	5
E-mail function	3
Full Maths	4
Maths (free functions)	4
Maths and Scripts (free functions)	6
Events (logical connections)	6
Custom specified screens	4
Fast scanning (20 ms/only with mV/V/mA)	5
Reports	3
Modbus Master	10
Secure WSD	3
Hardware Lock	2
Pwd Net Sync	5
AMS 2750 Process	5

Display Recorders

SIREC D300 and SIREC D400

Options

Options - Hardware

Alarm Card

- 4 or 8 outputs relay contacts SPCO 240 V
- 8 Digital I/O or 16 Digital I/O - SPNO 24 V DC
- Programmable alarm set points can be configured to activate up to 16 outputs for the SIREC D300 and 48 outputs for the SIREC D400.

Analog Output

- 2 or 4 outputs available per card
- Output type: 0-20 mA or 4-20 mA

Nema 4X/IP66

- Nema 4X/IP66 protection available as an option.

Portable Recorders

- Portable cases available as an accessory item.

Digital Input

Two digital input options are available:

- 2 inputs on 8 channel Alarm card, 8 inputs on 8 Digital I/O card and 16 inputs on a 16 Digital I/O card. The digital inputs allow users to initiate, from a remote location via a dry contact closure, selected recorder functions.

Pulse Counting

- Up to four counting inputs per board, are available to count signals up to 25 kHz (SIREC D300: max. 2 cards; SIREC D400: max. 6 cards).

24 V AC/DC or 48 V DC Power Supply

- 20 to 55 V DC
- 20 to 30 V AC

24 V DC Transmitter Power Supply

- Can supply up to 200 mA (SIREC D300) respectively 1 A (SIREC D400) to external transmitters.

Print Support

- Network printing from status, message and replay screens. Plus screen capture facility of process screens instantly using a basic USB standard PCL printer.

Dimensional drawings

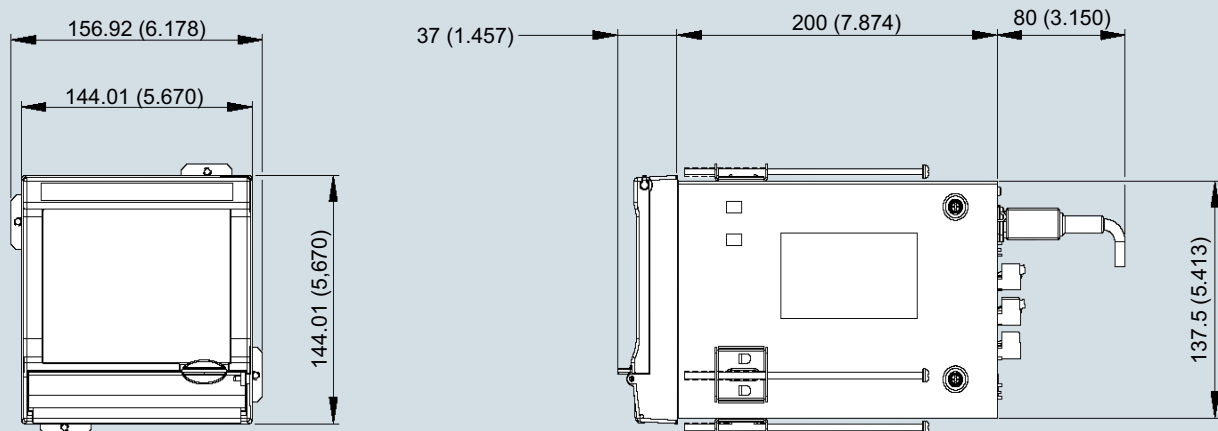

Two mounting brackets are supplied as standard

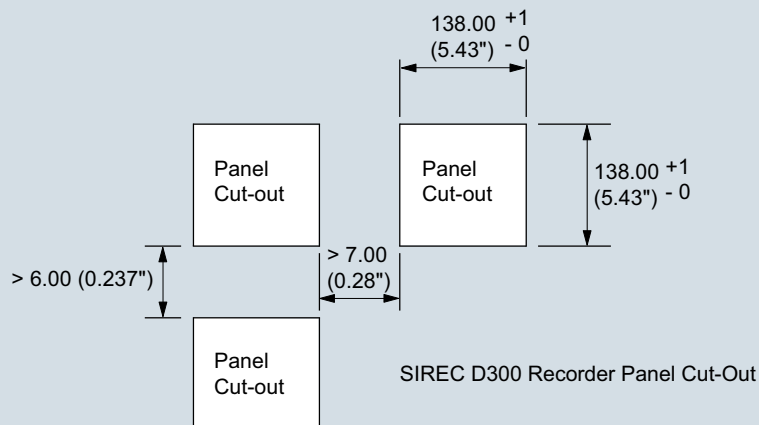

SIREC D300, dimensions in mm (inch) and panel cut-out

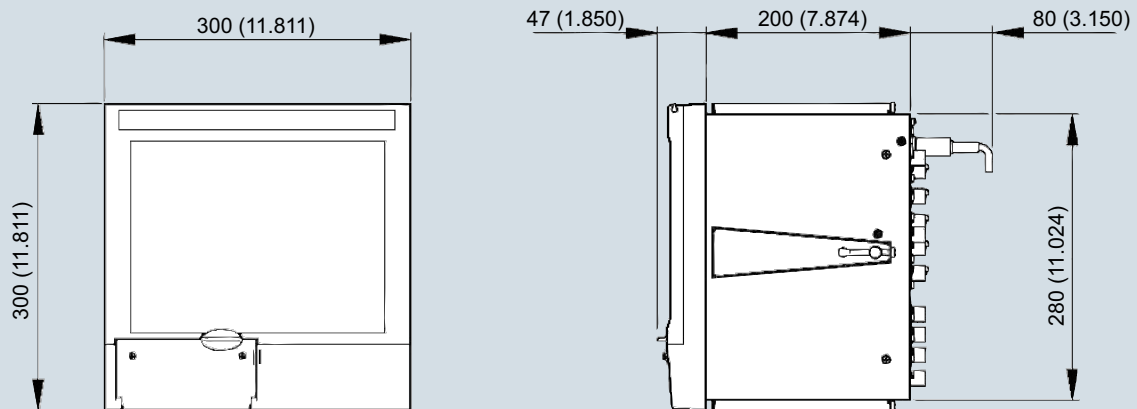

Two mounting brackets are supplied as standard

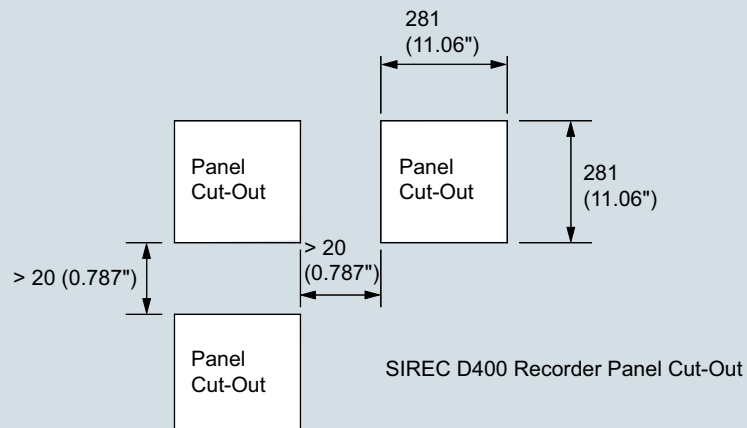

SIREC D400 Recorder Panel Cut-Out

SIREC D400, dimensions mm (inch) and panel cut-out

Display Recorders

SIREC D300 and SIREC D400

Schematics

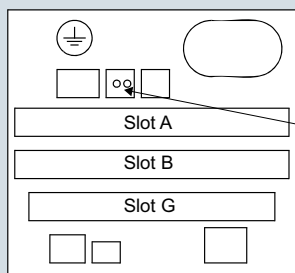

Analogue Output - Slot B only

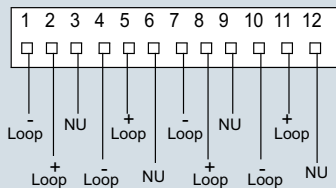

Pulse Input - Slots A and B

Connector position on right hand side

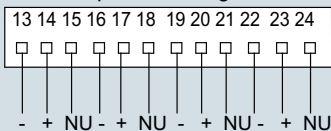

CJC Connector position

Analogue Input - Slots A and B

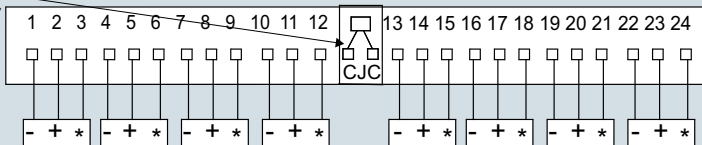

4 and 8 Relay Alarm - Slot G

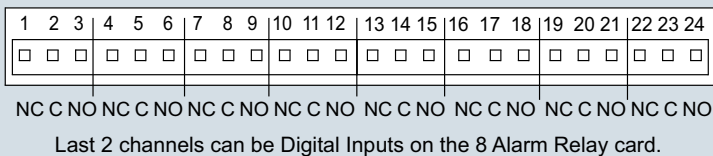

8 and 16 Digital Input/Output - Slot G

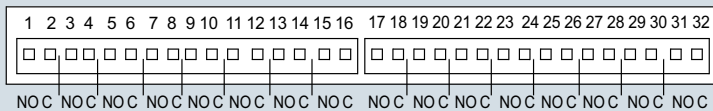

24 V Transmitter Power Supply

This is already fitted to the power supply card within the recorder. Connection is made via two 10-way connector at rear of unit.

Key: NO = Normally Open , C = Common , NC = Normally Closed, NU = Not Used

SIREC D300 - Terminal assignments and power requirements (rear of unit)

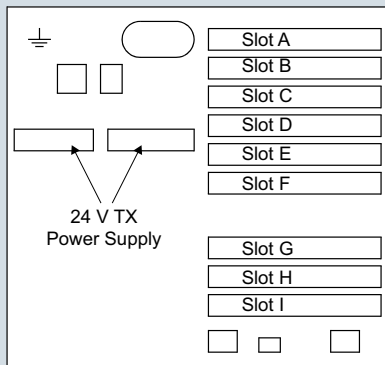

Analogue Output - Slots E and F

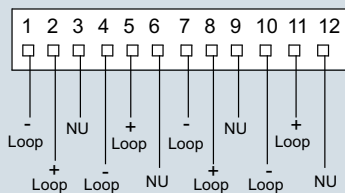

Pulse Input - Slots A to F

Connector position on right hand side

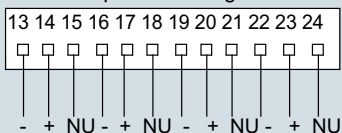

CJC Connector position

Analogue Input - Slots A to F

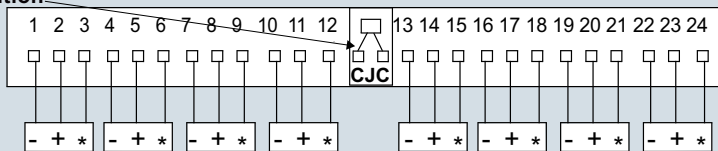

4 and 8 Relay Alarm - Slots G to I

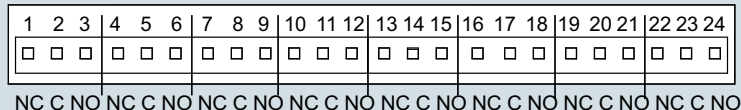

Last 2 channels can be Digital Inputs on the 8 Alarm Relay card.

8 and 16 Digital Input/Output - Slots G to I

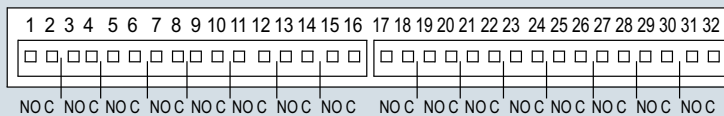

24 V Transmitter Power Supply

Connection is made via two 10-way connector at rear of unit.

Key: NO = Normally Open , C = Common , NC = Normally Closed, NU = Not Used

SIREC D400 - Terminal assignments and power requirements (rear of unit)

More information

Additional information is available in the Internet under:

<http://www.siemens.com/sirec>

Display Recorders

SIREC D application software

Overview

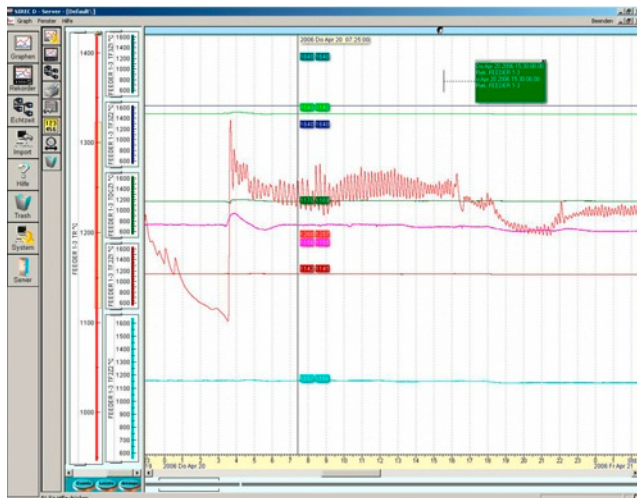

SIREC D-Viewer and SIREC D-Manager

The SIREC D-Viewer software is included in the scope of delivery of the recorder. It permits the graphical or numerical display and printout of measured values and data.

The SIREC D-Manager software package permits PC-based configuration and simulation of the recorder as well as the archiving, graphic display, printing and exporting of data with CSV format.

SIREC D-Server

SIREC D-Server is a network solution for data display and archiving as well as for communication with up to 256 recorders. An RS485 network or also the Ethernet TCP/IP option of the recorder is used for this, and permits direct interfacing to existing LANs. The standard package provides archiving, e-mail, graphics, printing and export functions

An integral OPC function permits export to software from other vendors in real-time mode.

Database Tool

This software application works with SIREC D-Manager and SIREC D-Server to provide safe administration of data with tools to archive, sort, move, copy and delete the data stored in local and remote databases.

The Database Tool software is supplied with SIREC D-Server.

SIREC D-Designer (only for SIREC D300 and SIREC D400)

The SIREC D-Designer permits the user to draft own graphic pages which are subsequently output on the recorder display. Any combination of display elements can be used such as trends, digital displays, bargraphs, bitmaps, digitized displays and plant displays. Various aspects of these elements can be modified if required to obtain a truly individual display.

The SIREC D-Designer software is compatible with both SIREC D300 and SIREC D400 recorders. Complete graphic pages can be loaded via diskette/PC card into any number of recorders. In this manner it is particularly easy to achieve consistent and standardized display of the process data.

Function

Comparison of functions of SIREC D-Viewer, Manager and Server

Functions	SIREC D-Viewer	SIREC D-Manager	SIREC D-Server
Importing of data from diskette	X	X	X
Graphic display of data	X	X	X
Upgrades available from Internet	X	X	X
Printout of all graphic data	X	X	X
Printout of all configuration data		X	X
PC-based configuration of graphic recorders		X	X
Configuration of fuzzy logging function		X	X
Configuration of event system		X	X
Archiving of data in protected databases		X	X
Exporting of measured data in CSV format		X	X
Exporting of online measured data with OPC			X
Communication with up to 256 recorders via RS485			X
Communication with recorders via Ethernet TCP/IP			X
Access to recorder data from a LAN			X
FTP and real-time Ethernet communication			X
User administration and password protection			X
Configuration of recorders via Ethernet			X
Audit trail manager			X

Technical specifications

System requirements	SIREC D-Viewer, SIREC D-Manager, SIREC D-Designer	SIREC D-Server
Processor	Pentium 1 GHz or higher	Pentium 1 GHz or higher
Main memory	512 MByte RAM (min. 512 MByte recommended)	512 MByte RAM (min. 512 MByte recommended)
Free hard disk space	50 MByte	2 GByte
Operating system	Microsoft Windows 2000, XP	Microsoft Windows 2000, XP
Monitor screen resolution	1024 x 768 (recommended minimum), high colour (16 bit), 24 bit recommended (SIREC D-Designer only)	1024 x 768 (recommended minimum), high colour (TCP IP installed)
Flash card reader or USB port	X	X
CD-ROM drive	X	X
Mouse	X	X
OPC server		OPC 2.0 compatible

Selection and ordering data

	Article No.
SIREC D software Evaluation software for SIREC D200/D300/ D400 incl. enabling for SIREC D-Viewer and manual for the software in German, English, French Software is included in delivery of recorder	7ND4800-8AA
Options / enabling of SIREC D software Code No. of software required	
Enabling of SIREC D-Manager	7ND4800-8BA
Enabling of SIREC D-Server	7ND4800-8CA
Enabling of SIREC D-Designer (only for SIREC D300 and SIREC D400)	7ND4801-8DA
Upgrading of SIREC D-Manager to SIREC D- Server	7ND4800-8EA

Appendix

Software licenses

Overview

Software types

Software requiring a license is categorized into types. The following software types have been defined:

- Engineering software
- Runtime software

Engineering software

This includes all software products for creating (engineering) user software, e.g. for configuring, programming, parameterizing, testing, commissioning or servicing.

Data generated with engineering software and executable programs can be duplicated for your own use or for use by third-parties free-of-charge.

Runtime software

This includes all software products required for plant/machine operation, e.g. operating system, basic system, system expansions, drivers, etc.

The duplication of the runtime software and executable programs created with the runtime software for your own use or for use by third-parties is subject to a charge.

You can find information about license fees according to use in the ordering data (e.g. in the catalog). Examples of categories of use include per CPU, per installation, per channel, per instance, per axis, per control loop, per variable, etc.

Information about extended rights of use for parameterization/configuration tools supplied as integral components of the scope of delivery can be found in the readme file supplied with the relevant product(s).

License types

Siemens Industry Automation & Drive Technologies offers various types of software license:

- Floating license
- Single license
- Rental license
- Rental floating license
- Trial license
- Demo license
- Demo floating license

Floating license

The software may be installed for internal use on any number of devices by the licensee. Only the concurrent user is licensed. The concurrent user is the person using the program. Use begins when the software is started. A license is required for each concurrent user.

Single license

Unlike the floating license, a single license permits only one installation of the software per license.

The type of use licensed is specified in the ordering data and in the Certificate of License (CoL). Types of use include for example per instance, per axis, per channel, etc.

One single license is required for each type of use defined.

Rental license

A rental license supports the "sporadic use" of engineering software. Once the license key has been installed, the software can be used for a specific period of time (the operating hours do not have to be consecutive).

One license is required for each installation of the software.

Rental floating license

The rental floating license corresponds to the rental license, except that a license is not required for each installation of the software. Rather, one license is required per object (for example, user or device).

Trial license

A trial license supports "short-term use" of the software in a non-productive context, e.g. for testing and evaluation purposes. It can be transferred to another license.

Demo license

The demo license support the "sporadic use" of engineering software in a non-productive context, for example, use for testing and evaluation purposes. It can be transferred to another license. After the installation of the license key, the software can be operated for a specific period of time, whereby usage can be interrupted as often as required.

One license is required per installation of the software.

Demo floating license

The demo floating license corresponds to the demo license, except that a license is not required for each installation of the software. Rather, one license is required per object (for example, user or device).

Certificate of license (CoL)

The CoL is the licensee's proof that the use of the software has been licensed by Siemens. A CoL is required for every type of use and must be kept in a safe place.

Downgrading

The licensee is permitted to use the software or an earlier version/release of the software, provided that the licensee owns such a version/release and its use is technically feasible.

Delivery versions

Software is constantly being updated. The following delivery versions

- PowerPack
- Upgrade

can be used to access updates.

Existing bug fixes are supplied with the ServicePack version.

PowerPack

PowerPacks can be used to upgrade to more powerful software. The licensee receives a new license agreement and CoL (Certificate of License) with the PowerPack. This CoL, together with the CoL for the original product, proves that the new software is licensed.

A separate PowerPack must be purchased for each original license of the software to be replaced.

Upgrade

An upgrade permits the use of a new version of the software on the condition that a license for a previous version of the product is already held.

The licensee receives a new license agreement and CoL with the upgrade. This CoL, together with the CoL for the previous product, proves that the new version is licensed.

A separate upgrade must be purchased for each original license of the software to be upgraded.

Overview

ServicePack

ServicePacks are used to debug existing products. ServicePacks may be duplicated for use as prescribed according to the number of existing original licenses.

License key

Siemens Industry Automation & Drive Technologies supplies software products with and without license keys.

The license key serves as an electronic license stamp and is also the "switch" for activating the software (floating license, rental license, etc.).

The complete installation of software products requiring license keys includes the program to be licensed (the software) and the license key (which represents the license).

Software Update Service (SUS)

As part of the SUS contract, all software updates for the respective product are made available to you free of charge for a period of one year from the invoice date. The contract will automatically be extended for one year if it is not canceled three months before it expires.

The possession of the current version of the respective software is a basic condition for entering into an SUS contract.

You can download explanations concerning license conditions from www.siemens.com/automation/salesmaterial-as/catalog/en/terms_of_trade_en.pdf

Appendix

Conditions of sale and delivery

1. General Provisions

By using this catalog you can acquire hardware and software products described therein from Siemens AG subject to the following Terms and Conditions of Sale and Delivery (hereinafter referred to as "T&C"). Please note that the scope, the quality and the conditions for supplies and services, including software products, by any Siemens entity having a registered office outside Germany, shall be subject exclusively to the General Terms and Conditions of the respective Siemens entity. The following T&C apply exclusively for orders placed with Siemens Aktiengesellschaft, Germany.

1.1 For customers with a seat or registered office in Germany

For customers with a seat or registered office in Germany, the following applies subordinate to the T&C:

- the "General Terms of Payment"¹⁾ and,
- for software products, the "General License Conditions for Software Products for Automation and Drives for Customers with a Seat or Registered Office in Germany"¹⁾ and,
- for other supplies and services, the "General Conditions for the Supply of Products and Services of the Electrical and Electronics Industry"¹⁾.

1.2 For customers with a seat or registered office outside Germany

For customers with a seat or registered office outside Germany, the following applies subordinate to the T&C:

- the "General Terms of Payment"¹⁾ and,
- for software products, the "General License Conditions for Software Products for Automation and Drives for Customers with a Seat or Registered Office outside of Germany"¹⁾ and
- for other supplies and/or services, the "General Conditions for Supplies of Siemens Industry for Customers with a Seat or Registered Office outside of Germany"¹⁾.

2. Prices

The prices are in € (Euro) ex point of delivery, exclusive of packaging.

The sales tax (value added tax) is not included in the prices. It shall be charged separately at the respective rate according to the applicable statutory legal regulations.

Prices are subject to change without prior notice. We will charge the prices valid at the time of delivery.

To compensate for variations in the price of raw materials (e.g. silver, copper, aluminum, lead, gold, dysprosium and neodym), surcharges are calculated on a daily basis using the so-called metal factor for products containing these raw materials. A surcharge for the respective raw material is calculated as a supplement to the price of a product if the basic official price of the raw material in question is exceeded.

The metal factor of a product indicates the basic official price (for those raw materials concerned) as of which the surcharges on the price of the product are applied, and with what method of calculation.

An exact explanation of the metal factor can be downloaded at: www.siemens.com/automation/salesmaterial-as/catalog/en/terms_of_trade_en.pdf

To calculate the surcharge (except in the cases of dysprosium and neodym), the official price from the day prior to that on which the order was received or the release order was effected is used.

To calculate the surcharge applicable to dysprosium and neodym ("rare earths"), the corresponding three-month basic average price in the quarter prior to that in which the order was received or the release order was effected is used with a one-month buffer (details on the calculation can be found in the explanation of the metal factor).

3. Additional Terms and Conditions

The dimensions are in mm. In Germany, according to the German law on units in measuring technology, data in inches apply only to devices for export.

Illustrations are not binding.

Insofar as there are no remarks on the individual pages of this catalog - especially with regard to data, dimensions and weights given - these are subject to change without prior notice.

4. Export regulations

We shall not be obligated to fulfill any agreement if such fulfillment is prevented by any impediments arising out of national or international foreign trade or customs requirements or any embargoes and/or other sanctions.

Export of goods listed in this catalog may be subject to licensing requirements. We will indicate in the delivery details whether licenses are required under German, European and US export lists. Goods labeled with "AL" not equal to "N" are subject to European or German export authorization when being exported out of the EU. Goods labeled with "ECCN" not equal to "N" are subject to US re-export authorization.

The export indications can be viewed in advance in the description of the respective goods on the Industry Mall, our online catalog system. Only the export labels "AL" and "ECCN" indicated on order confirmations, delivery notes and invoices are authoritative.

Even without a label, or with label "AL:N" or "ECCN:N", authorization may be required i .a. due to the final disposition and intended use of goods.

If you transfer goods (hardware and/or software and/or technology as well as corresponding documentation, regardless of the mode of provision) delivered by us or works and services (including all kinds of technical support) performed by us to a third party worldwide, you must comply with all applicable national and international (re-)export control regulations.

If required for the purpose of conducting export control checks, you (upon request by us) shall promptly provide us with all information pertaining to the particular end customer, final disposition and intended use of goods delivered by us respectively works and services provided by us, as well as to any export control restrictions existing in this relation.

The products listed in this catalog may be subject to European/ German and/or US export regulations. Any export requiring approval is therefore subject to authorization by the relevant authorities.

Errors excepted and subject to change without prior notice.

1) The text of the Terms and Conditions of Siemens AG can be downloaded at www.siemens.com/automation/salesmaterial-as/catalog/en/terms_of_trade_en.pdf

Further information can be obtained from our branch offices listed at www.siemens.com/automation-contact

Interactive Catalog on DVD Products for Automation and Drives	<i>Catalog</i> CA 01	Low-Voltage Power Distribution and Electrical Installation Technology SENTRON · SIVACON · ALPHA Protection, Switching, Measuring and Monitoring Devices, Switchboards and Distribution Systems Standards-Compliant Components for Photovoltaic Plants Electrical Components for the Railway Industry TÜV-certified Power Monitoring System Components for Industrial Control Panels according to UL Standards 3WT Air Circuit Breakers up to 4000 A 3VT Molded Case Circuit Breakers up to 1600 A <i>Digital: SIVACON System Cubicles, System Lighting and System Air-Conditioning</i> <i>Digital: ALPHA Distribution Systems</i> ALPHA FIX Terminal Blocks SIVACON S4 Power Distribution Boards SIVACON 8PS Busbar Trunking Systems <i>Digital: DELTA Switches and Socket Outlets</i>	<i>Catalog</i> LV 10 LV 11 LV 12 LV 14 LV 16 LV 35 LV 36 LV 50 LV 51 LV 52 LV 56 LV 70 ET D1
Building Control GAMMA Building Control	ET G1	Motion Control SINUMERIK 840 Equipment for Machine Tools SINUMERIK 808 Equipment for Machine Tools SINUMERIK 828 Equipment for Machine Tools SIMOTION Equipment for Production Machines <i>Digital: Drive and Control Components for Cranes</i>	NC 62 NC 81.1 NC 82 PM 21 CR 1
Drive Systems SINAMICS G130 Drive Converter Chassis Units SINAMICS G150 Drive Converter Cabinet Units SINAMICS GM150, SINAMICS SM150 Medium-Voltage Converters SINAMICS PERFECT HARMONY GH180 Medium-Voltage Air-Cooled Drives (Germany Edition) SINAMICS G180 Converters – Compact Units, Cabinet Systems, Cabinet Units Air-Cooled and Liquid-Cooled SINAMICS S120 Chassis Format Units and Cabinet Modules SINAMICS S150 Converter Cabinet Units SINAMICS S120 and SIMOTICS SINAMICS DCM DC Converter, Control Module SINAMICS DCM Cabinet SINAMICS Inverters for Single-Axis Drives and SIMOTICS Motors <i>Digital: SINAMICS G120P and SINAMICS G120P Cabinet pump, fan, compressor converters</i> LOHER VARIO High Voltage Motors Flameproof, Type Series 1PS4, 1PS5, 1MV4 and 1MV5 Frame Size 355 to 1000, Power Range 80 to 7100 kW Three-Phase Induction Motors SIMOTICS HV, SIMOTICS TN • Series H-compact • Series H-compact PLUS High Voltage Three-phase Induction Motors SIMOTICS HV Series A-compact PLUS Three-Phase Induction Motors SIMOTICS HV, Series H-compact Synchronous Motors with Permanent-Magnet Technology, HT-direct DC Motors SIMOREG DC MASTER 6RA70 Digital Chassis Converters SIMOREG K 6RA22 Analog Chassis Converters <i>Digital: SIMOREG DC MASTER 6RM70 Digital Converter Cabinet Units</i> SIMOVERT PM Modular Converter Systems SIEMOSYN Motors MICROMASTER 420/430/440 Inverters MICROMASTER 411/COMBIMASTER 411 <u>Low-Voltage Three-Phase-Motors</u> SIMOTOCS S-1FG1 Servo geared motors SIMOTICS Low-Voltage Motors SIMOTICS FD Low-Voltage Motors LOHER Low-Voltage Motors MOTOX Geared Motors SIMOGEAR Geared Motors SIMOGEAR Gearboxes with adapter <u>Mechanical Driving Machines</u> FLENDER Standard Couplings FLENDER High Performance Couplings FLENDER Backlash-free Couplings FLENDER SIP Standard industrial planetary gear units	D 11 D 12 D 15.1 D 18.1 D 21.3 D 21.4 D 23.1 D 23.2 D 31 D 35 D 83.2 D 84.1 D 84.9 D 86.1 D 86.2 DA 12 DA 21.1 DA 21.2 DA 22 DA 45 DA 48 DA 51.2 DA 51.3 D 41 D 81.1 D 81.8 D 83.1 D 87.1 MD 50.1 MD 50.11 MD 10.1 MD 10.2 MD 10.3 MD 31.1	Power Supply SITOP Power supply	KT 10.1
Process Instrumentation and Analytics <i>Digital: Field Instruments for Process Automation</i> <i>Digital: Display Recorders SIREC D</i> <i>Digital: SIPART Controllers and Software</i> Products for Weighing Technology Process Analytical Instruments <i>Digital: Process Analytics, Components for Continuous Emission Monitoring</i>	FI 01 MP 20 MP 31 WT 10 AP 01 AP 11	Safety Integrated Safety Technology for Factory Automation	SI 10
		SIMATIC HMI / PC-based Automation Human Machine Interface Systems/ PC-based Automation	ST 80/ ST PC
		SIMATIC Ident Industrial Identification Systems	ID 10
		SIMATIC Industrial Automation Systems Products for Totally Integrated Automation SIMATIC PCS 7 Process Control System System components SIMATIC PCS 7 Process Control System Technology components Add-ons for the SIMATIC PCS 7 Process Control System	ST 70 ST PCS 7 ST PCS 7 T ST PCS 7 AO
		SIMATIC NET Industrial Communication	IK PI
		SIRIUS Industrial Controls <i>Digital: SIRIUS Industrial Controls</i>	IC 10
		<i>Digital: These catalogs are only available as a PDF.</i>	
		Information and Download Center Digital versions of the catalogs are available on the Internet at: www.siemens.com/industry/infocenter There you'll find additional catalogs in other languages. Please note the section "Downloading catalogs" on page "Online services" in the appendix of this catalog.	

Get more information

All the latest information on field instruments for process automation can be found on the internet at www.siemens.com/processinstrumentation

Siemens AG
Process Industries and Drives
Process Automation
76181 Karlsruhe
Germany

© Siemens AG 2016
Subject to change without prior notice
Article No. PDF (E86060-K6020-E101-A5-7600)
Produced in Germany

The information provided in this catalog contains merely general descriptions or characteristics of performance which in case of actual use do not always apply as described or which may change as a result of further development of the products. An obligation to provide the respective characteristics shall only exist if expressly agreed in the terms of contract. Availability and technical specifications are subject to change without notice.

All product designations may be trademarks or product names of Siemens AG or supplier companies whose use by third parties for their own purposes could violate the rights of the owners.

Security information

Siemens provides products and solutions with industrial security functions that support the secure operation of plants, systems, machines and networks.

In order to protect plants, systems, machines and networks against cyber threats, it is necessary to implement – and continuously maintain – a holistic, state-of-the-art industrial security concept. Siemens' products and solutions only form one element of such a concept.

Customer is responsible to prevent unauthorized access to its plants, systems, machines and networks. Systems, machines and components should only be connected to the enterprise network or the internet if and to the extent necessary and with appropriate security measures (e.g. use of firewalls and network segmentation) in place.

Additionally, Siemens' guidance on appropriate security measures should be taken into account. For more information about industrial security, please visit <http://www.siemens.com/industrialsecurity>.

Siemens' products and solutions undergo continuous development to make them more secure. Siemens strongly recommends to apply product updates as soon as available and to always use the latest product versions. Use of product versions that are no longer supported, and failure to apply latest updates may increase customer's exposure to cyber threats.

To stay informed about product updates, subscribe to the Siemens Industrial Security RSS Feed under <http://www.siemens.com/industrialsecurity>.